

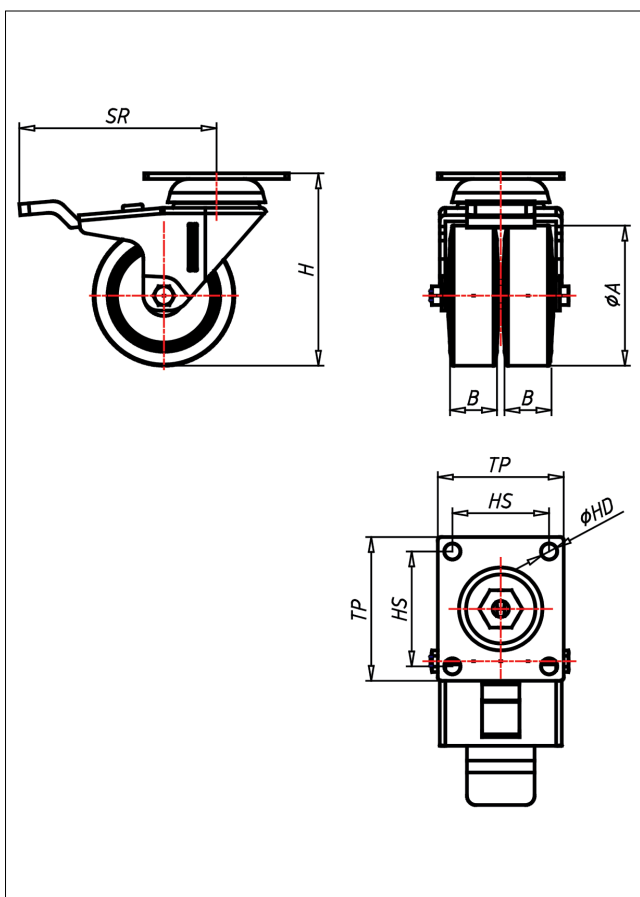

# 321 PT-GK/G/GL/GKL

## Lenkrolle mit Totalfeststeller



320P-G



LENKROLLE	LENKROLLE MIT TOTALFESTSTELLER																					
																						
<ul style="list-style-type: none"> <li>• spurfrei</li> <li>• geräuscharmer Lauf</li> <li>• großer Fahrkomfort</li> <li>• beständig gegen verdünnte Säuren</li> </ul> Thermoplastisches Elastomer Felge Polyamid 6 → Seite 268	 <ul style="list-style-type: none"> <li>• zweifaches Kugellager - vernietet</li> <li>• Radachse verschraubt - gesichert</li> <li>• verzinkt-chromatiert</li> </ul> → Seite	AUSWAHLHILFE: <table border="0"> <tr> <td>leicht lenkend</td> <td><input type="checkbox"/></td> <td><input checked="" type="checkbox"/></td> <td><input checked="" type="checkbox"/></td> </tr> <tr> <td>verschleißarm</td> <td><input type="checkbox"/></td> <td><input checked="" type="checkbox"/></td> <td><input checked="" type="checkbox"/></td> </tr> <tr> <td>stoßfest</td> <td><input checked="" type="checkbox"/></td> <td><input type="checkbox"/></td> <td><input type="checkbox"/></td> </tr> <tr> <td>bodenschonend</td> <td><input type="checkbox"/></td> <td><input checked="" type="checkbox"/></td> <td><input checked="" type="checkbox"/></td> </tr> <tr> <td>witterungsbeständig</td> <td><input checked="" type="checkbox"/></td> <td><input type="checkbox"/></td> <td><input type="checkbox"/></td> </tr> </table>	leicht lenkend	<input type="checkbox"/>	<input checked="" type="checkbox"/>	<input checked="" type="checkbox"/>	verschleißarm	<input type="checkbox"/>	<input checked="" type="checkbox"/>	<input checked="" type="checkbox"/>	stoßfest	<input checked="" type="checkbox"/>	<input type="checkbox"/>	<input type="checkbox"/>	bodenschonend	<input type="checkbox"/>	<input checked="" type="checkbox"/>	<input checked="" type="checkbox"/>	witterungsbeständig	<input checked="" type="checkbox"/>	<input type="checkbox"/>	<input type="checkbox"/>
leicht lenkend	<input type="checkbox"/>	<input checked="" type="checkbox"/>	<input checked="" type="checkbox"/>																			
verschleißarm	<input type="checkbox"/>	<input checked="" type="checkbox"/>	<input checked="" type="checkbox"/>																			
stoßfest	<input checked="" type="checkbox"/>	<input type="checkbox"/>	<input type="checkbox"/>																			
bodenschonend	<input type="checkbox"/>	<input checked="" type="checkbox"/>	<input checked="" type="checkbox"/>																			
witterungsbeständig	<input checked="" type="checkbox"/>	<input type="checkbox"/>	<input type="checkbox"/>																			

### Technische Details

<b>ORDERNO (Artikel-nummer)</b>	321 PT 75 GK
<b>WDAB (Rad-Ø A x Breite B / mm)</b>	75x25+25
<b>LC (Tragkraft / kg)</b>	90
<b>H (Bauhöhe H / mm)</b>	103
<b>TP (Plattengröße / mm)</b>	77x67
<b>HS (Lochabstand / mm)</b>	61.5x51.5
<b>HD (Loch-Ø / mm)</b>	8.5
<b>SR (Schwenkradius / mm)</b>	105
<b>WB (Radlager)</b>	Kugellager