

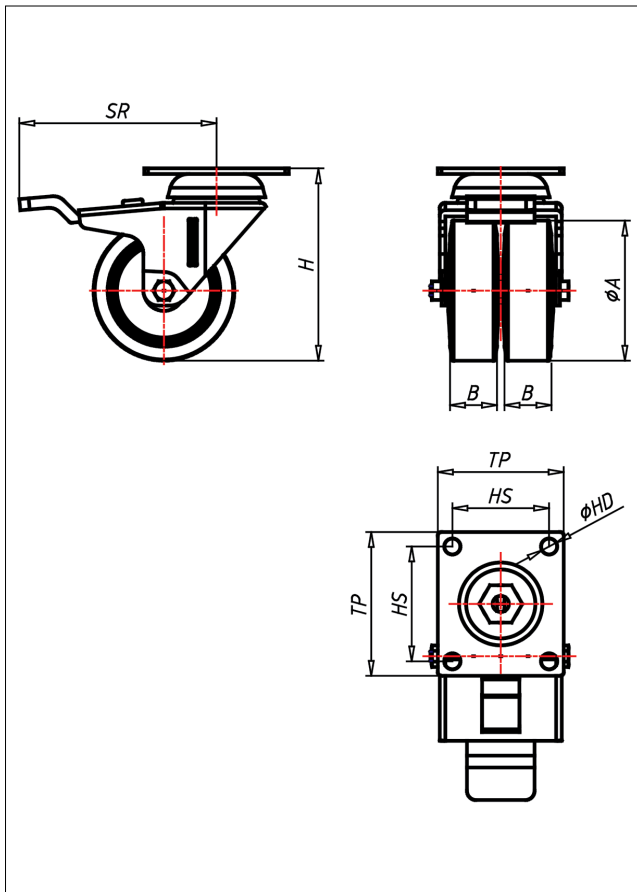

321 PT-GK/G/GL/GKL

Lenkrolle mit Totalfeststeller



320P-G



LENKROLLE	LENKROLLE MIT TOTALFESTSTELLER																					
<ul style="list-style-type: none"> • spurfrei • geräuscharmer Lauf • großer Fahrkomfort • beständig gegen verdünnte Säuren Thermoplastisches Elastomer Felge Polyamid 6 → Seite 268	zweifaches Kugellager - vernietet Radachse verschraubt - gesichert verzinkt-chromatiert → Seite	AUSWAHLHILFE: <table border="1"> <tr> <td>leicht lenkend</td> <td>-</td> <td>+</td> <td>++</td> </tr> <tr> <td>verschleißarm</td> <td>-</td> <td>+</td> <td>++</td> </tr> <tr> <td>stoßfest</td> <td>-</td> <td>+</td> <td>++</td> </tr> <tr> <td>bodenschonend</td> <td>-</td> <td>+</td> <td>++</td> </tr> <tr> <td>witterungsbeständig</td> <td>-</td> <td>+</td> <td>++</td> </tr> </table>	leicht lenkend	-	+	++	verschleißarm	-	+	++	stoßfest	-	+	++	bodenschonend	-	+	++	witterungsbeständig	-	+	++
leicht lenkend	-	+	++																			
verschleißarm	-	+	++																			
stoßfest	-	+	++																			
bodenschonend	-	+	++																			
witterungsbeständig	-	+	++																			

Technische Details

ORDERNO (Artikel-nummer)	321 PT 75 GKL
WDAB (Rad-Ø A x Breite B / mm)	75x25+25
LC (Tragkraft / kg)	90
H (Bauhöhe H / mm)	103
TP (Plattengröße / mm)	77x67
HS (Lochabstand / mm)	61.5x51.5
HD (Loch-Ø / mm)	8.5
SR (Schwenkradius / mm)	105
WB (Radlager)	Kugellager