

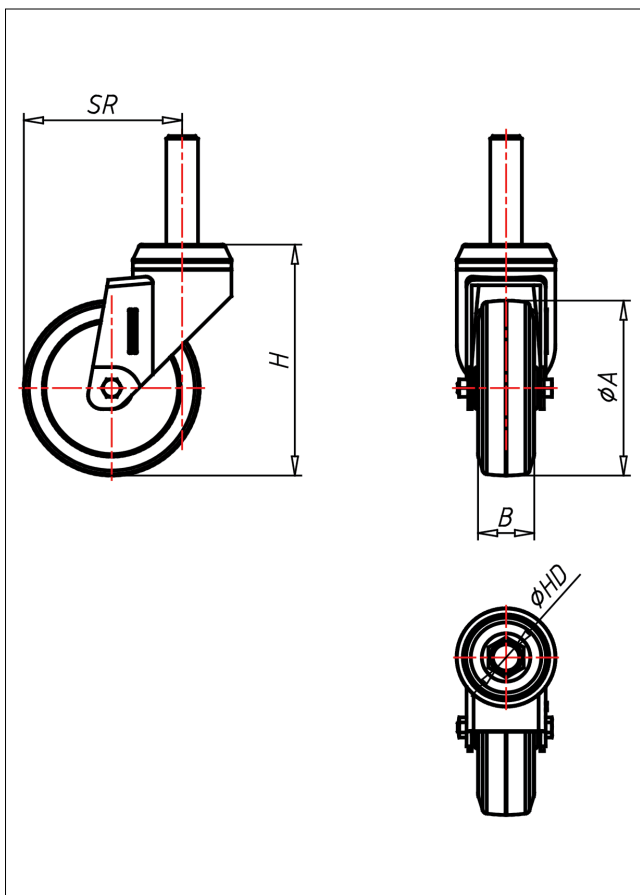

# 330LXZ-EL

## Lenkrolle

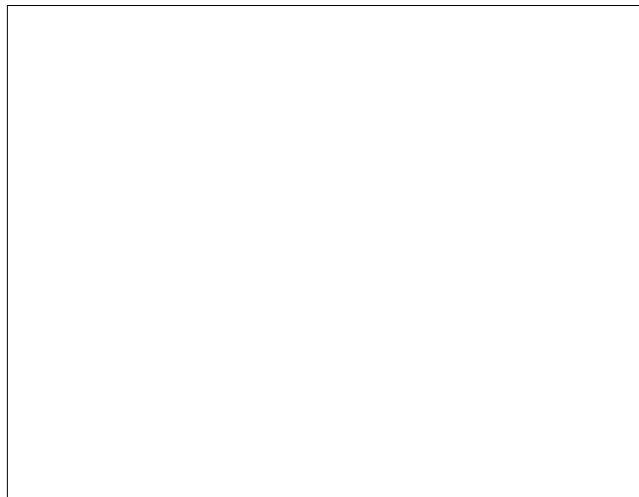

### Technische Details

ORDERNO (Artikel-nummer)	330LX Z18 102 EL
WDAB (Rad- $\phi$ A x Breite B / mm)	100x32
LC (Tragkraft / kg)	90
H (Bauhöhe H / mm)	132
ZAPFEN ( / mm)	18x62
QB (Quer-bohrung / mm)	M8 auf 19
SR (Schwenkradius / mm)	90
WB (Radlager)	Polyamid-Gleitlager