

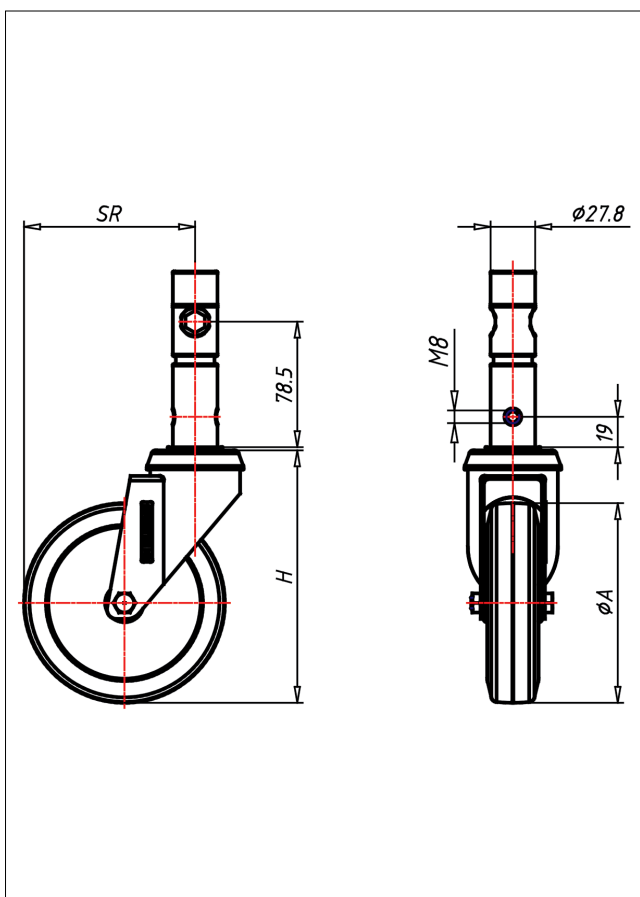

# 390 S-TPK

## Lenkrolle mit Totalfeststeller



### 390-TP



Mit Total oder Total- und Richtungsfeststeller	<ul style="list-style-type: none"> <li>geräuscharmer Lauf</li> <li>geringer Rollwiderstand</li> <li>abrieb- und reißfest</li> <li>hohe Stoßfestigkeit</li> <li>spulfrei</li> <li>sehr beständig gegen viele aggressive Medien</li> </ul>	<p><b>zweifaches Kugellager</b> spritzwassergeschützt Radachse verschraubt - gesichert, verzinkt Dauerfettfüllung in der Schaltmechanik</p> <p>→ Seite</p>
<p>Thermoplastische Elastomer Bandage eisengrau RAL 7011, 95 Shore A**, SPURFREI Kunststoff-Radkörper und Fadenschutz silbergrau RAL 7001, Präzisionskugellager</p>		

### Technische Details

<b>ORDERNO (Artikel-nummer)</b>	390 S 150 TPK
<b>WDAB (Rad-Ø A x Breite B / mm)</b>	150x32
<b>LC (Tragkraft / kg)</b>	120
<b>H (Bauhöhe H / mm)</b>	184
<b>STEM (Zapfen / mm)</b>	27.8
<b>HS (Lochabstand / mm)</b>	M8x19
<b>SR (Schwenkradius / mm)</b>	126
<b>WB (Radlager)</b>	Kugellager