

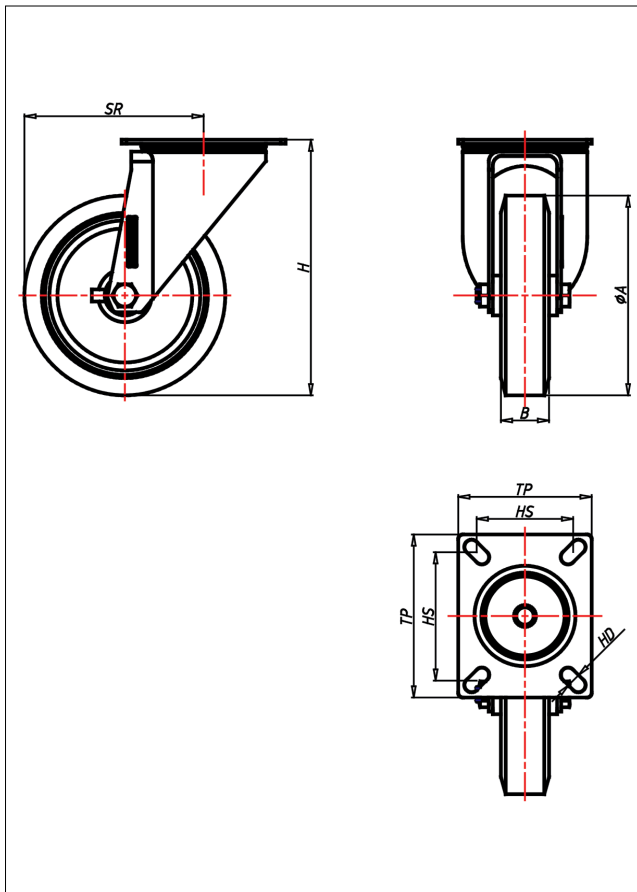

CD/CS/CSS/CL-A/AK/AB

Lenkrolle



CD-A



LENKROLLE	LENKROLLE MIT TOTALFESTSTELLER	BOCKROLLE																				
 <ul style="list-style-type: none"> • geräuscharmer Lauf • geringer Rollwiderstand • abrieb- und reißfest • hohe Stoßfestigkeit • leichte Reinigung • sehr beständig gegen viele aggressive Medien <p>Guss-Polyurethan Felge Polyamid 6 → Seite 252</p> 	 <p>zweifaches Kugellager - vernietet Stahlkugeln gehärtet Dichtungsring, Radachse verschraubt, verzinkt- chrompassiviert</p> <p>→ Seite 62</p>	 <p>AUSWAHLHILFE:</p> <table border="1"> <tr> <td>leicht lenkend</td> <td>-</td> <td>+</td> <td>++</td> </tr> <tr> <td>verschleißarm</td> <td>x</td> <td></td> <td></td> </tr> <tr> <td>stoßfest</td> <td></td> <td>x</td> <td></td> </tr> <tr> <td>bodenschonend</td> <td></td> <td></td> <td>x</td> </tr> <tr> <td>witterungsbeständig</td> <td>x</td> <td></td> <td></td> </tr> </table>	leicht lenkend	-	+	++	verschleißarm	x			stoßfest		x		bodenschonend			x	witterungsbeständig	x		
leicht lenkend	-	+	++																			
verschleißarm	x																					
stoßfest		x																				
bodenschonend			x																			
witterungsbeständig	x																					

Technische Details

ORDERNO (Artikel-nummer)	CD 150 AK
WDAB (Rad-Ø A x Breite B / mm)	150x40
LC (Tragkraft / kg)	200
H (Bauhöhe H / mm)	181
TP (Plattengröße / mm)	135x110
HS (Lochabstand / mm)	105x80
HD (Loch-Ø / mm)	11
SR (Schwenkradius / mm)	126
WB (Radlager)	Kugellager