

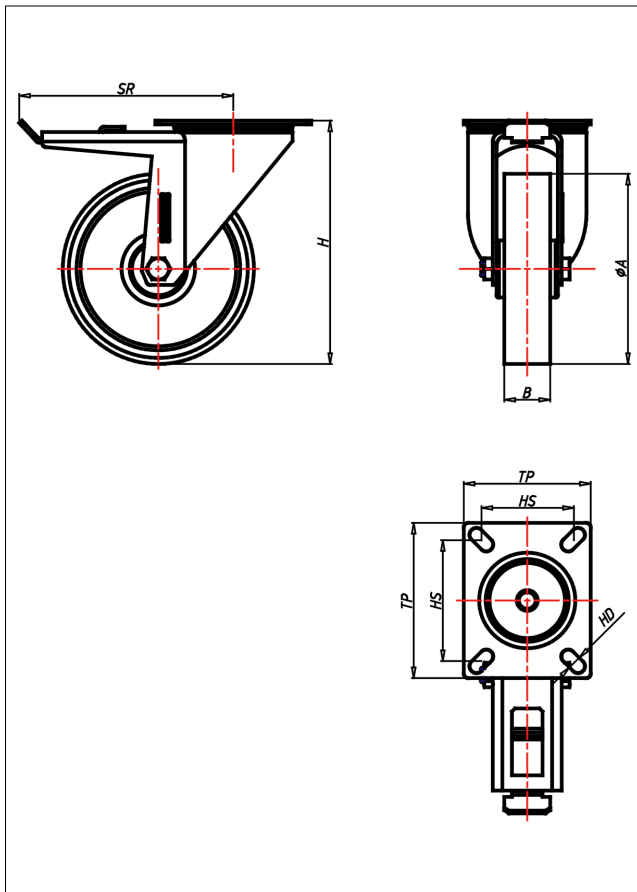

CDT/CST/CSST/CLT-AL/ALB/ALK

Lenkrolle mit Totalfeststeller



CD-AL



| LENKROLLE | LENKROLLE MIT TOTALFESTSTELLER | BOCKROLLE | | | | | | | | | | | | | | | | | | |
|--|---|--|---|---|----|----------------|---|---|---------------|---|---|----------|---|---|---------------|---|---|---------------------|---|---|
| | | | | | | | | | | | | | | | | | | | | |
| <ul style="list-style-type: none"> • geringer Rollwiderstand • abrieb- und reißfest • leichte Reinigung • sehr beständig gegen viele aggressive Medien Spritzguss-Polyurethan Felge Polyamid 6 → Seite 253 | <ul style="list-style-type: none"> • zweifaches Kugellager - vernietet • Stahlkugeln gehärtet • Dichtungsring, Radachse verschraubt, verzinkt-chrompassiviert → Seite 62 | AUSWAHLHILFE: <table border="1"> <tr> <td>-</td><td>+</td><td>++</td></tr> <tr> <td>leicht lenkend</td><td>X</td><td>X</td></tr> <tr> <td>verschleißarm</td><td>X</td><td>X</td></tr> <tr> <td>stoßfest</td><td>X</td><td>X</td></tr> <tr> <td>bodenschonend</td><td>X</td><td>X</td></tr> <tr> <td>witterungsbeständig</td><td>X</td><td>X</td></tr> </table> | - | + | ++ | leicht lenkend | X | X | verschleißarm | X | X | stoßfest | X | X | bodenschonend | X | X | witterungsbeständig | X | X |
| - | + | ++ | | | | | | | | | | | | | | | | | | |
| leicht lenkend | X | X | | | | | | | | | | | | | | | | | | |
| verschleißarm | X | X | | | | | | | | | | | | | | | | | | |
| stoßfest | X | X | | | | | | | | | | | | | | | | | | |
| bodenschonend | X | X | | | | | | | | | | | | | | | | | | |
| witterungsbeständig | X | X | | | | | | | | | | | | | | | | | | |

Technische Details

| | |
|---------------------------------------|-------------|
| ORDERNO (Artikel-nummer) | CDT 100 ALB |
| WDAB (Rad-Ø A x Breite B / mm) | 100x30 |
| LC (Tragkraft / kg) | 120 |
| H (Bauhöhe H / mm) | 128 |
| TP (Plattengröße / mm) | 102x83 |
| HS (Lochabstand / mm) | 80x60 |
| HD (Loch-Ø / mm) | 9 |
| SR (Schwenkradius / mm) | 108 |
| WB (Radlager) | Rollenlager |