

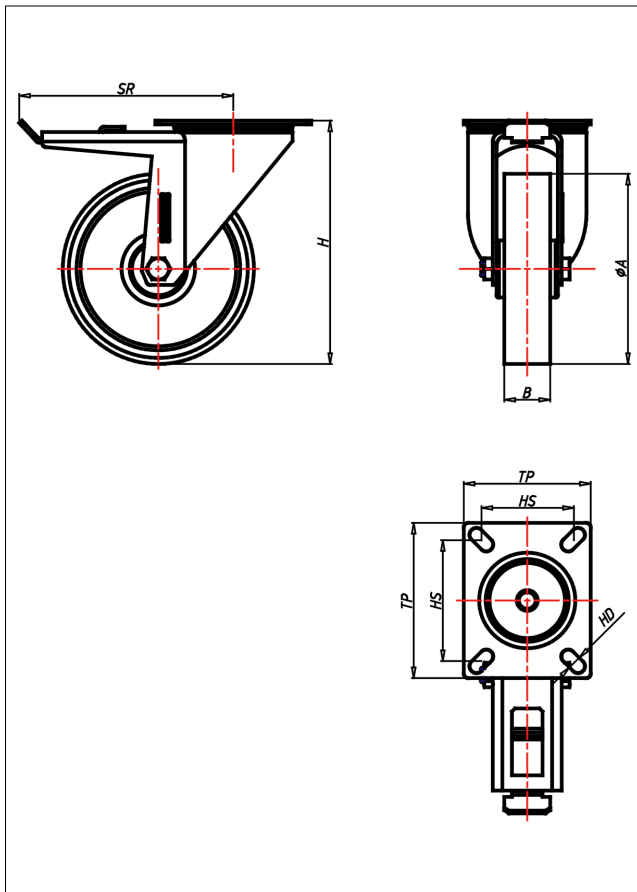

CDT/CST/CSST/CLT-AL/ALB/ALK

Lenkrolle mit Totalfeststeller



CD-AL



LENKROLLE	LENKROLLE MIT TOTALFESTSTELLER	BOCKROLLE																		
<ul style="list-style-type: none"> • geringer Rollwiderstand • abrieb- und reißfest • leichte Reinigung • sehr beständig gegen viele aggressive Medien Spritzguss-Polyurethan Felge Polyamid 6 → Seite 253	<ul style="list-style-type: none"> • zweifaches Kugellager - vernietet • Stahlkugeln gehärtet • Dichtungsring, Radachse verschraubt, verzinkt-chrompassiviert → Seite 62	AUSWAHLHILFE: <table border="0"> <tr> <td>-</td><td>+</td><td>++</td></tr> <tr> <td>leicht lenkend</td><td>X</td><td>X</td></tr> <tr> <td>verschleißarm</td><td>X</td><td>X</td></tr> <tr> <td>stoßfest</td><td>X</td><td>X</td></tr> <tr> <td>bodenschonend</td><td>X</td><td>X</td></tr> <tr> <td>witterungsbeständig</td><td>X</td><td>X</td></tr> </table>	-	+	++	leicht lenkend	X	X	verschleißarm	X	X	stoßfest	X	X	bodenschonend	X	X	witterungsbeständig	X	X
-	+	++																		
leicht lenkend	X	X																		
verschleißarm	X	X																		
stoßfest	X	X																		
bodenschonend	X	X																		
witterungsbeständig	X	X																		

Technische Details

ORDERNO (Artikel-nummer)	CDT 125 AL
WDAB (Rad-Ø A x Breite B / mm)	125x30
LC (Tragkraft / kg)	120
H (Bauhöhe H / mm)	154
TP (Plattengröße / mm)	102x83
HS (Lochabstand / mm)	80x60
HD (Loch-Ø / mm)	9
SR (Schwenkradius / mm)	108
WB (Radlager)	Nylon-Gleitlager