

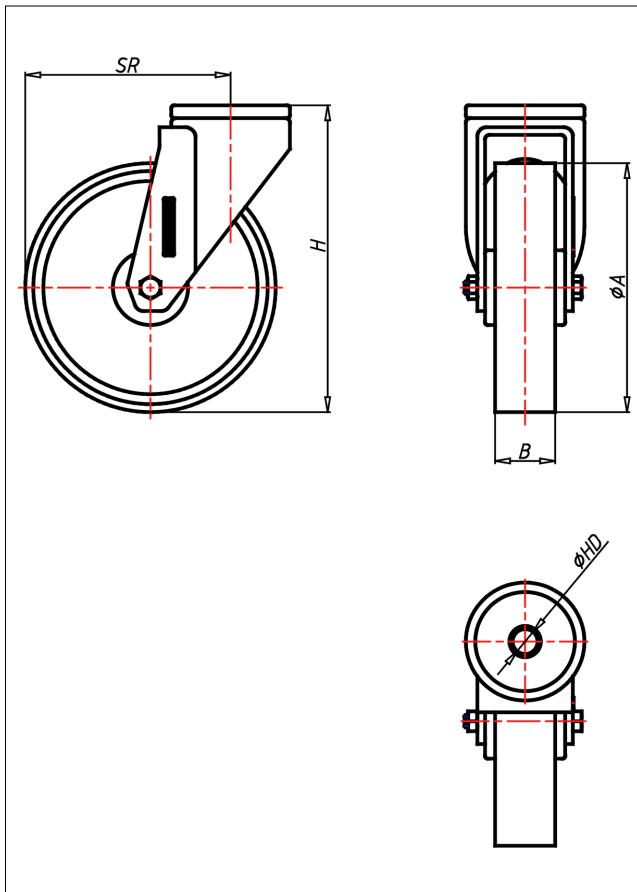

# CR/CRS-AL/ALB/ALK

## Lenkrolle



### CR-AL



LENKROLLE	LENKROLLE MIT TOTALFESTSTELLER	
		
<ul style="list-style-type: none"> <li>• geringer Rollwiderstand</li> <li>• abrieb- und reißfest</li> <li>• leichte Reinigung</li> <li>• sehr beständig gegen viele aggressive Medien</li> </ul> Spritzguss-Polyurethan Felge Polyamid 6 → Seite 253	 zweifaches Kugellager - vernietet Stahlkugeln gehärtet Radachse verschraubt, verzinkt → Seite 62	<b>AUSWAHLHILFE:</b> <ul style="list-style-type: none"> <li>leicht lenkend <input checked="" type="checkbox"/></li> <li>verschleißarm <input checked="" type="checkbox"/></li> <li>stoßfest <input checked="" type="checkbox"/></li> <li>bodenschonend <input checked="" type="checkbox"/></li> <li>witterungsbeständig <input checked="" type="checkbox"/></li> </ul>

### Technische Details

<b>ORDERNO (Artikel-nummer)</b>	CR 100 AL
<b>WDAB (Rad-Ø A x Breite B / mm)</b>	100x30
<b>LC (Tragkraft / kg)</b>	120
<b>H (Bauhöhe H / mm)</b>	128
<b>HD (Loch-Ø / mm)</b>	12.5
<b>SR (Schwenkradius / mm)</b>	87
<b>WB (Radlager)</b>	Nylon-Gleitlager