

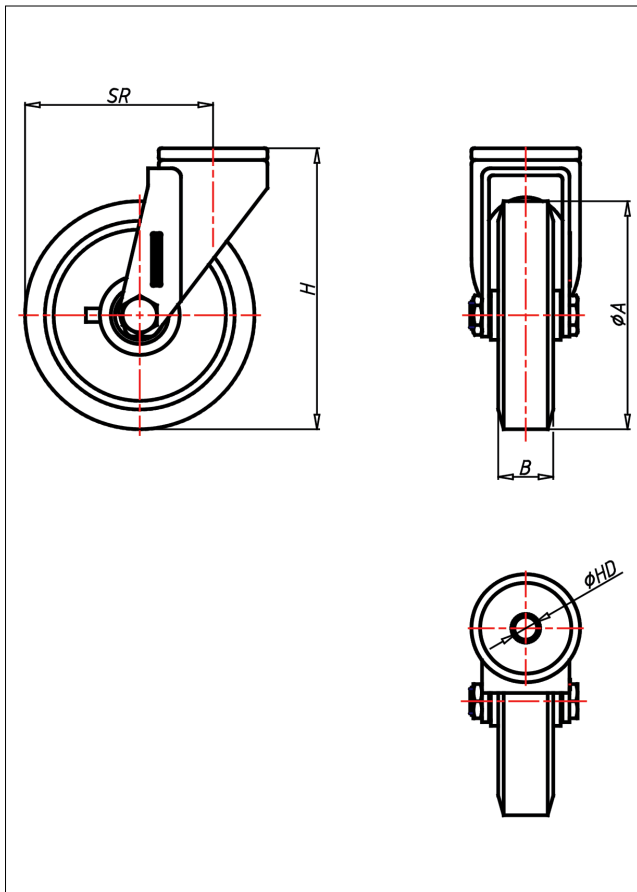

# CR/CRS-A/AK/AB

## Lenkrolle



### CR-A



SWIVEL CASTOR	SWIVEL CASTOR WITH TOTAL LOCK	
<ul style="list-style-type: none"> <li>• silent in motion</li> <li>• low rolling resistance</li> <li>• high abrasion and tear resistance</li> <li>• high resistance to shocks</li> <li>• easy to clean</li> <li>• good chemical resistance</li> </ul> Cast-polyurethane High quality nylon wheel centre → page 252	Medium duty bolt hole castor, finish: electro-zinc plated, swivel fork with single bolt hole, double ball bearing - revited, hardened steel balls, wheel axle bolted, total lock → page 62	SELECTION CRITERIA: swivels easily <input type="checkbox"/> <input checked="" type="checkbox"/> <input type="checkbox"/> <input type="checkbox"/> wear resistant <input type="checkbox"/> <input checked="" type="checkbox"/> <input type="checkbox"/> <input type="checkbox"/> shock proof <input type="checkbox"/> <input checked="" type="checkbox"/> <input type="checkbox"/> <input type="checkbox"/> floor protective <input type="checkbox"/> <input type="checkbox"/> <input checked="" type="checkbox"/> <input type="checkbox"/> weather proof <input type="checkbox"/> <input type="checkbox"/> <input checked="" type="checkbox"/> <input type="checkbox"/>

### Technische Details

<b>ORDERNO (Artikel-nummer)</b>	CR 125 AK
<b>WDAB (Rad-Ø A x Breite B / mm)</b>	125x30
<b>LC (Tragkraft / kg)</b>	120
<b>H (Bauhöhe H / mm)</b>	154
<b>HD (Loch-Ø / mm)</b>	12.5
<b>SR (Schwenkradius / mm)</b>	102.5
<b>WB (Radlager)</b>	Kugellager