

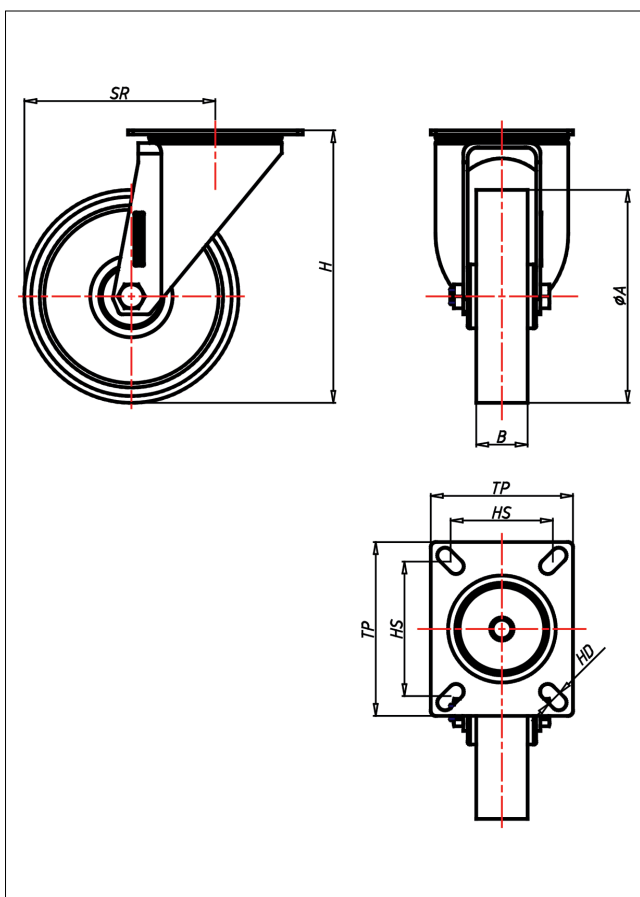

# CD/CS/CSS/CL- AL/ALB/ALK Lenkrolle



## CD-AL



LENKROLLE	LENKROLLE MIT TOTALFESTSTELLER	BOCKROLLE
 <ul style="list-style-type: none"> <li>• geringer Rollwiderstand</li> <li>• abrieb- und reißfest</li> <li>• leichte Reinigung</li> <li>• sehr beständig gegen viele aggressive Medien</li> </ul> <p>Spritzguss-Polyurethan Felge Polyamid 6 → Seite 253</p> 	 <p>zweifaches Kugellager - vernietet Stahlkugeln gehärtet Dichtungsring, Radachse verschraubt, verzinkt- chrompassiviert</p> <p>→ Seite 62</p>	 <p>AUSWAHLHILFE: - + ++</p> <ul style="list-style-type: none"> <li>leicht lenkend X</li> <li>verschleißarm X</li> <li>stoßfest X</li> <li>bodenschonend X</li> <li>witterungsbeständig X</li> </ul>

## Technische Details

ORDERNO (Artikel-nummer)	CSS 125 AL
WDAB (Rad-Ø A x Breite B / mm)	125x30
LC (Tragkraft / kg)	200
H (Bauhöhe H / mm)	160
TP (Plattengröße / mm)	135x110
HS (Lochabstand / mm)	105x80
HD (Loch-Ø / mm)	11
SR (Schwenkradius / mm)	111.5
WB (Radlager)	Nylon-Gleitlager