

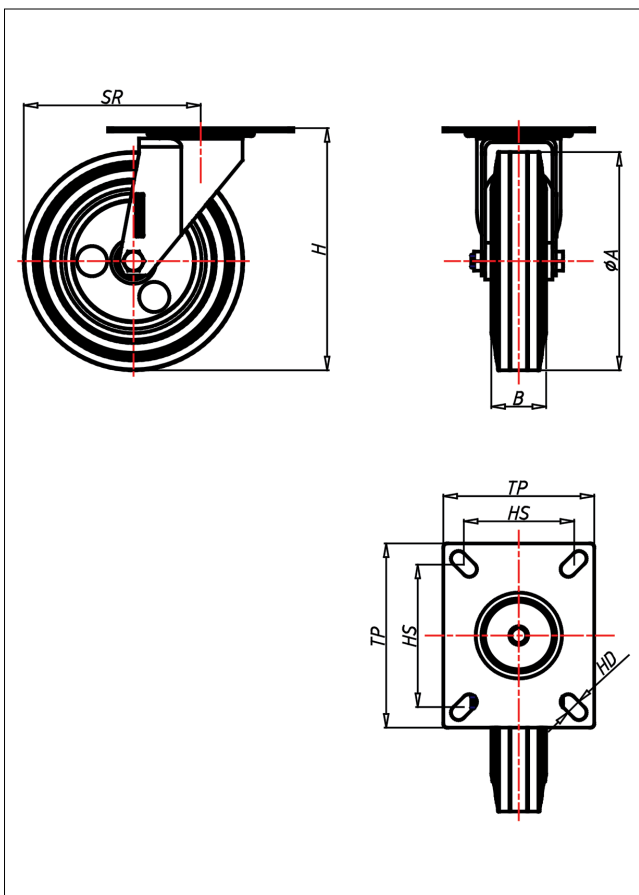

CD/CS/CSS-ELB/ELK

Lenkrolle



CD-EL



LENKROLLE	LENKROLLE MIT TOTALFESTSTELLER	BOCKROLLE																									
<ul style="list-style-type: none"> • elektrisch leitfähig • Widerstand <math><10^4 \Omega</math> • geräuscharmer Lauf • großer Fahrkomfort • beständig gegen verdünnte Säuren <p>Vollgummi schwarz Felge Stahlblech verzinkt → Seite 257</p>	<p>zweifaches Kugellager - vernietet Stahlkugeln gehärtet Dichtungsring Radachse verschraubt, verzinkt-chrompassiviert</p> <p>→ Seite 62</p>	<p>AUSWAHLHILFE:</p> <table border="0"> <tr> <td>leicht lenkend</td> <td>☐</td> <td>☐</td> <td>☐</td> <td>☐</td> </tr> <tr> <td>verschleißarm</td> <td>☐</td> <td>☐</td> <td>☐</td> <td>☐</td> </tr> <tr> <td>stoßfest</td> <td>☐</td> <td>☐</td> <td>☐</td> <td>☐</td> </tr> <tr> <td>bodenschonend</td> <td>☐</td> <td>☐</td> <td>☐</td> <td>☐</td> </tr> <tr> <td>witterungsbeständig</td> <td>☐</td> <td>☐</td> <td>☐</td> <td>☐</td> </tr> </table>	leicht lenkend	☐	☐	☐	☐	verschleißarm	☐	☐	☐	☐	stoßfest	☐	☐	☐	☐	bodenschonend	☐	☐	☐	☐	witterungsbeständig	☐	☐	☐	☐
leicht lenkend	☐	☐	☐	☐																							
verschleißarm	☐	☐	☐	☐																							
stoßfest	☐	☐	☐	☐																							
bodenschonend	☐	☐	☐	☐																							
witterungsbeständig	☐	☐	☐	☐																							

Technische Details

ORDERNO (Artikel-nummer)	CSS 125 ELB
WDAB (Rad-Ø A x Breite B / mm)	125x38
LC (Tragkraft / kg)	100
H (Bauhöhe H / mm)	160
TP (Plattengröße / mm)	135x110
HS (Lochabstand / mm)	105x80
HD (Loch-Ø / mm)	11
SR (Schwenkradius / mm)	111.5
WB (Radlager)	Rollenlager