

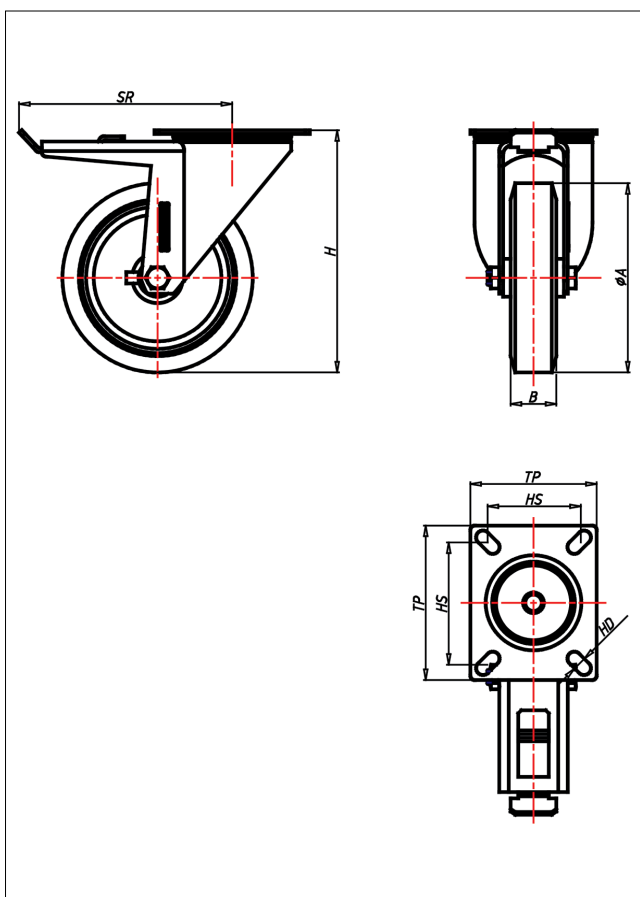

CDT/CST/CSST/CLT-A/AK/AB

Lenkrolle mit Totalfeststeller



CD-A



LENKROLLE	LENKROLLE MIT TOTALFESTSTELLER	BOCKROLLE																				
<ul style="list-style-type: none"> • geräuscharmer Lauf • geringer Rollwiderstand • abrieb- und reißfest • hohe Stoßfestigkeit • leichte Reinigung • sehr beständig gegen viele aggressive Medien Guss-Polyurethan Felge Polyamid 6 → Seite 252	zweifaches Kugellager - vernietet Stahlkugeln gehärtet Dichtungsring, Radachse verschraubt, verzinkt- chrompassiviert → Seite 62	AUSWAHLHILFE: <table border="0"> <tr><td>leicht lenkend</td><td>+</td><td>+</td><td>+</td></tr> <tr><td>verschleißarm</td><td>x</td><td>x</td><td>x</td></tr> <tr><td>stoßfest</td><td>+</td><td>+</td><td>+</td></tr> <tr><td>bodenschonend</td><td>+</td><td>+</td><td>+</td></tr> <tr><td>witterungsbeständig</td><td>x</td><td>x</td><td>x</td></tr> </table>	leicht lenkend	+	+	+	verschleißarm	x	x	x	stoßfest	+	+	+	bodenschonend	+	+	+	witterungsbeständig	x	x	x
leicht lenkend	+	+	+																			
verschleißarm	x	x	x																			
stoßfest	+	+	+																			
bodenschonend	+	+	+																			
witterungsbeständig	x	x	x																			

Technische Details

ORDERNO (Artikel-nummer)	CST 125 AK
WDAB (Rad-Ø A x Breite B / mm)	125x30
LC (Tragkraft / kg)	170
H (Bauhöhe H / mm)	160
TP (Plattengröße / mm)	102x83
HS (Lochabstand / mm)	80x60
HD (Loch-Ø / mm)	9
SR (Schwenkradius / mm)	140
WB (Radlager)	Kugellager