

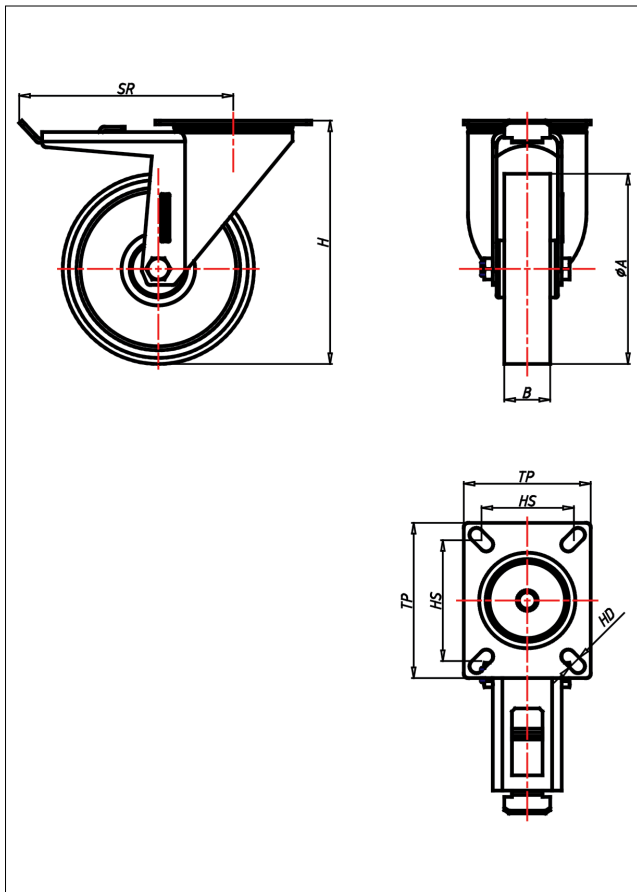

# CDT/CST/CSST/CLT-AL/ALB/ALK

Lenkrolle mit Totalfeststeller



## CD-AL



LENKROLLE	LENKROLLE MIT TOTALFESTSTELLER	BOCKROLLE																		
<ul style="list-style-type: none"> <li>• geringer Rollwiderstand</li> <li>• abrieb- und reißfest</li> <li>• leichte Reinigung</li> <li>• sehr beständig gegen viele aggressive Medien</li> </ul> Spritzguss-Polyurethan Felge Polyamid 6 → Seite 253	zweifaches Kugellager - vernietet Stahlkugeln gehärtet Dichtungsring, Radachse verschraubt, verzinkt- chrompassiviert → Seite 62	AUSWAHLHILFE: <table border="0"> <tr> <td>-</td><td>+</td><td>++</td></tr> <tr> <td>leicht lenkend</td><td>X</td><td>X</td></tr> <tr> <td>verschleißarm</td><td>X</td><td>X</td></tr> <tr> <td>stoßfest</td><td>X</td><td>X</td></tr> <tr> <td>bodenschonend</td><td>X</td><td>X</td></tr> <tr> <td>witterungsbeständig</td><td>X</td><td>X</td></tr> </table>	-	+	++	leicht lenkend	X	X	verschleißarm	X	X	stoßfest	X	X	bodenschonend	X	X	witterungsbeständig	X	X
-	+	++																		
leicht lenkend	X	X																		
verschleißarm	X	X																		
stoßfest	X	X																		
bodenschonend	X	X																		
witterungsbeständig	X	X																		

## Technische Details

<b>ORDERNO (Artikel-nummer)</b>	CST 125 AL
<b>WDAB (Rad-Ø A x Breite B / mm)</b>	125x30
<b>LC (Tragkraft / kg)</b>	170
<b>H (Bauhöhe H / mm)</b>	160
<b>TP (Plattengröße / mm)</b>	102x83
<b>HS (Lochabstand / mm)</b>	80x60
<b>HD (Loch-Ø / mm)</b>	9
<b>SR (Schwenkradius / mm)</b>	140
<b>WB (Radlager)</b>	Nylon-Gleitlager