

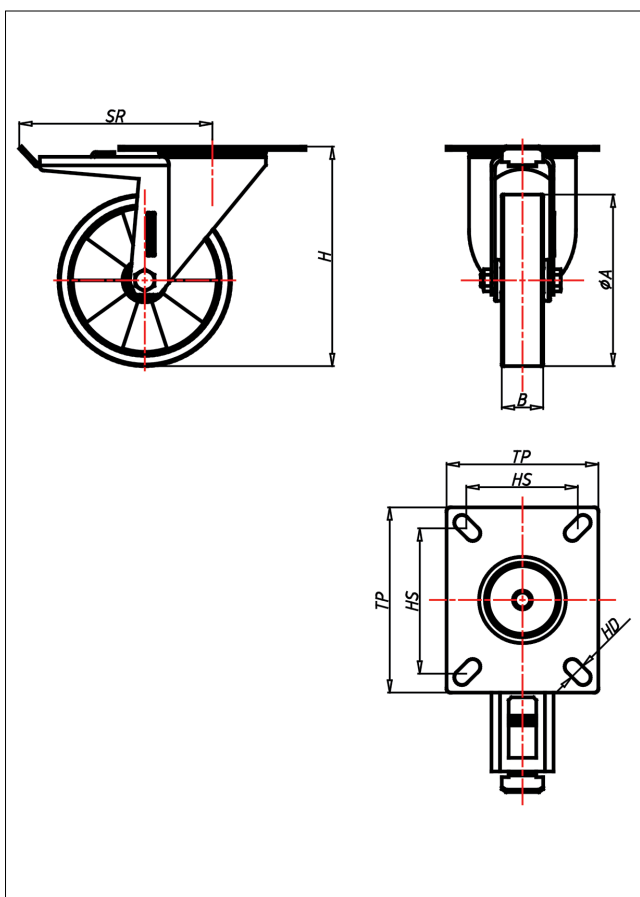

# CDT/CST/CSST/CLT- TLK/TLB

Lenkrolle mit Totalfeststeller

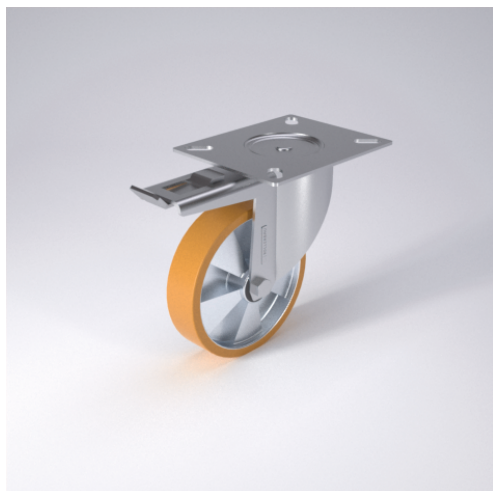

## CD-TL



LENKROLLE	LENKROLLE MIT TOTALFESTSTELLER	BOCKROLLE															
<ul style="list-style-type: none"> <li>• geräuscharmer Lauf</li> <li>• geringer Rollwiderstand</li> <li>• abrieb- und reißfest</li> <li>• hohe Stoßfestigkeit</li> <li>• sehr beständig gegen viele aggressive Medien</li> </ul> <p>Guss-Polyurethan Felge Spritzguss-Aluminium- Legierung → Seite 250</p>	<p>zweifaches Kugellager - vernietet Stahlkugeln gehärtet Dichtungsring, Radachse verschraubt, verzinkt- chrompassiviert</p> <p>→ Seite 62</p>	<p>AUSWAHLHILFE:</p> <table border="0"> <tr> <td>leicht lenkend</td> <td>+</td> <td>+</td> </tr> <tr> <td>verschleißarm</td> <td>x</td> <td>x</td> </tr> <tr> <td>stoßfest</td> <td>x</td> <td>x</td> </tr> <tr> <td>bodenschonend</td> <td>+</td> <td>x</td> </tr> <tr> <td>witterungsbeständig</td> <td>x</td> <td>+</td> </tr> </table>	leicht lenkend	+	+	verschleißarm	x	x	stoßfest	x	x	bodenschonend	+	x	witterungsbeständig	x	+
leicht lenkend	+	+															
verschleißarm	x	x															
stoßfest	x	x															
bodenschonend	+	x															
witterungsbeständig	x	+															

## Technische Details

<b>ORDERNO (Artikel-nummer)</b>	CST 125 TLB
<b>WDAB (Rad-Ø A x Breite B / mm)</b>	125x30
<b>LC (Tragkraft / kg)</b>	170
<b>H (Bauhöhe H / mm)</b>	160
<b>TP (Plattengröße / mm)</b>	102x83
<b>HS (Lochabstand / mm)</b>	80x60
<b>HD (Loch-Ø / mm)</b>	9
<b>SR (Schwenkradius / mm)</b>	140
<b>WB (Radlager)</b>	Kugellager