

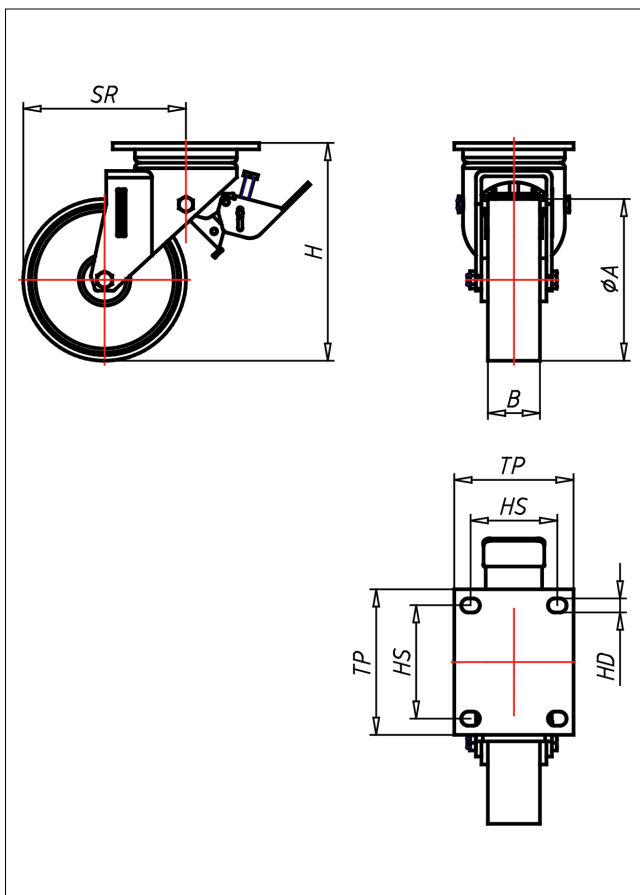

EDT-PK/P

Lenkrolle mit Totalfeststeller



ED-P



LENKROLLE	LENKROLLE MIT TOTALFESTSTELLER	BOCKROLLE																								
<ul style="list-style-type: none"> • leichter Lauf auf glatten Böden • stoß- und schlagfest • hohe Abriebfestigkeit • leicht zu reinigen • sehr beständig gegen viele aggressive Medien Polyamid 6 - 1. Wahl → Seite 272	<p>Schrägröll- und Axialkugellager, staubgeschützt, sehr starker Zentralbolzen, Mutter gesichert, Schmiernippel Ausführung – lackiert → Seite 26</p>	AUSWAHLHILFE: <table border="0"> <tr> <td>-</td><td>+</td><td>+</td><td>+</td></tr> <tr> <td>leicht lenkend</td><td>+</td><td>+</td><td>+</td></tr> <tr> <td>verschleißarm</td><td>+</td><td>+</td><td>+</td></tr> <tr> <td>stoßfest</td><td>+</td><td>+</td><td>+</td></tr> <tr> <td>bodenschonend</td><td>+</td><td>+</td><td>+</td></tr> <tr> <td>witterungsbeständig</td><td>+</td><td>+</td><td>+</td></tr> </table>	-	+	+	+	leicht lenkend	+	+	+	verschleißarm	+	+	+	stoßfest	+	+	+	bodenschonend	+	+	+	witterungsbeständig	+	+	+
-	+	+	+																							
leicht lenkend	+	+	+																							
verschleißarm	+	+	+																							
stoßfest	+	+	+																							
bodenschonend	+	+	+																							
witterungsbeständig	+	+	+																							

Technische Details

ORDERNO (Artikel-nummer)	EDT 151 PK
WDAB (Rad-Ø A x Breite B / mm)	150x48
LC (Tragkraft / kg)	900
H (Bauhöhe H / mm)	195
TP (Plattengröße / mm)	135x110
HS (Lochabstand / mm)	105x80
HD (Loch-Ø / mm)	13
SR (Schwenkradius / mm)	150
WB (Radlager)	Kugellager