

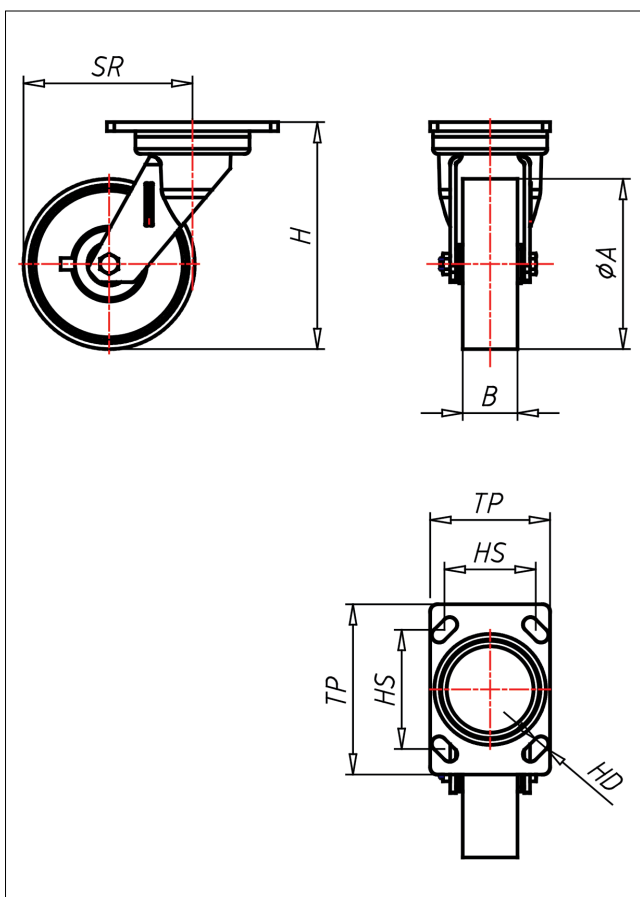

# GT-PK/P

## Lenkrolle



GT-P



LENKROLLE	RADFESTSTELLER	BOCKROLLE																				
<ul style="list-style-type: none"> <li>• leichter Lauf auf glatten Böden</li> <li>• stoß- und schlagfest</li> <li>• hohe Abriebfestigkeit</li> <li>• leicht zu reinigen</li> <li>• sehr beständig gegen viele aggressive Medien</li> </ul> Polyamid 6 - 1. Wahl → Seite 272	Schwerlastlenkgehäuse ohne Mittelbolzen mit gehärtetem Drehkranz und gehärteten Stahlkugeln, geschmiedet und getempert → Seite 42	AUSWAHLHILFE: <table border="1"> <tr> <td>leicht lenkend</td> <td>-</td> <td>+</td> <td>++</td> </tr> <tr> <td>verschleißarm</td> <td>x</td> <td></td> <td></td> </tr> <tr> <td>stoßfest</td> <td></td> <td>x</td> <td>x</td> </tr> <tr> <td>bodenschonend</td> <td></td> <td>x</td> <td></td> </tr> <tr> <td>witterungsbeständig</td> <td></td> <td>x</td> <td>x</td> </tr> </table>	leicht lenkend	-	+	++	verschleißarm	x			stoßfest		x	x	bodenschonend		x		witterungsbeständig		x	x
leicht lenkend	-	+	++																			
verschleißarm	x																					
stoßfest		x	x																			
bodenschonend		x																				
witterungsbeständig		x	x																			

### Technische Details

<b>ORDERNO (Artikel-nummer)</b>	GT 126 PK
<b>WDAB (Rad-Ø A x Breite B / mm)</b>	125x45
<b>LC (Tragkraft / kg)</b>	600
<b>H (Bauhöhe H / mm)</b>	165
<b>TP (Plattengröße / mm)</b>	138x110
<b>HS (Lochabstand / mm)</b>	105x80
<b>HD (Loch-Ø / mm)</b>	10
<b>SR (Schwenkradius / mm)</b>	114.5
<b>WB (Radlager)</b>	Kugellager