

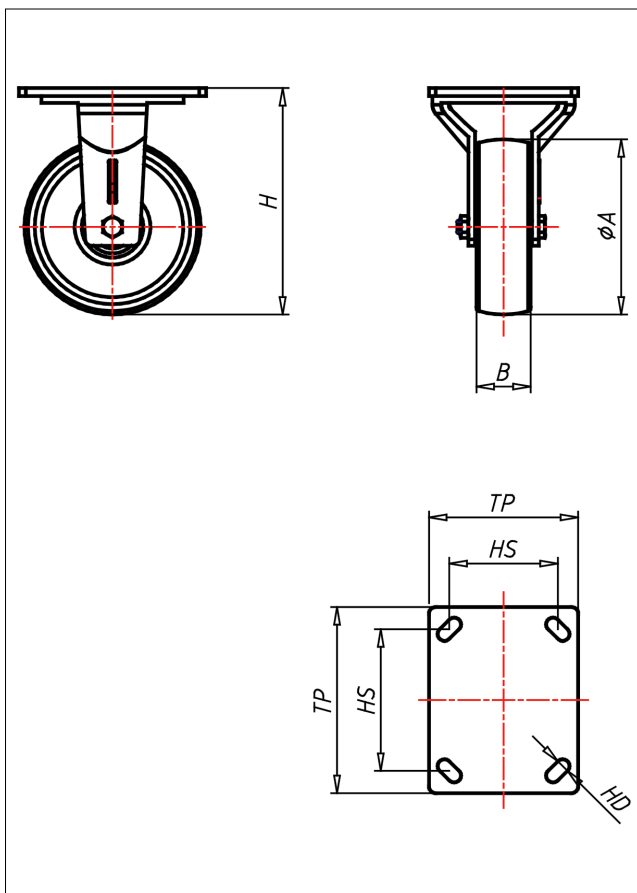

# GTF-QK/CIB/CI/CIK

## Bockrolle

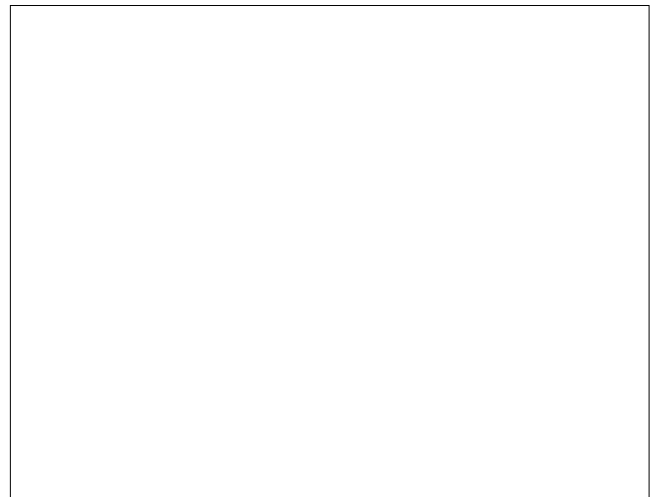

### GT-CI



LENKROLLE	RADFESTSTELLER	BOCKROLLE																				
<ul style="list-style-type: none"> <li>• leichter Lauf auf glatten Böden</li> <li>• sehr hohe Tragkraft</li> <li>• sehr abriebfest</li> </ul> <p>Gusseisen überdreht, lackiert</p> <p>→ Seite 270</p>	<p>Schwerlastlenkgehäuse ohne Mittelbolzen mit gehärtetem Drehkranz und gehärteten Stahlkugeln, geschmiedet und getempert</p> <p>→ Seite 42</p>	<p>AUSWAHLHILFE:</p> <table border="1"> <tr> <td>leicht lenkend</td> <td>X</td> <td>X</td> <td>X</td> </tr> <tr> <td>verschleißarm</td> <td>X</td> <td>X</td> <td>X</td> </tr> <tr> <td>stoßfest</td> <td>X</td> <td>X</td> <td>X</td> </tr> <tr> <td>bodenschonend</td> <td>X</td> <td>X</td> <td>X</td> </tr> <tr> <td>witterungsbeständig</td> <td>X</td> <td>X</td> <td>X</td> </tr> </table>	leicht lenkend	X	X	X	verschleißarm	X	X	X	stoßfest	X	X	X	bodenschonend	X	X	X	witterungsbeständig	X	X	X
leicht lenkend	X	X	X																			
verschleißarm	X	X	X																			
stoßfest	X	X	X																			
bodenschonend	X	X	X																			
witterungsbeständig	X	X	X																			

### Technische Details

<b>ORDERNO (Artikel-nummer)</b>	GTF 100 CI
<b>WDAB (Rad-Ø A x Breite B / mm)</b>	100x38
<b>LC (Tragkraft / kg)</b>	450
<b>H (Bauhöhe H / mm)</b>	140
<b>TP (Plattengröße / mm)</b>	138x110
<b>HS (Lochabstand / mm)</b>	105x80
<b>HD (Loch-Ø / mm)</b>	10
<b>WB (Radlager)</b>	Gleitlager