

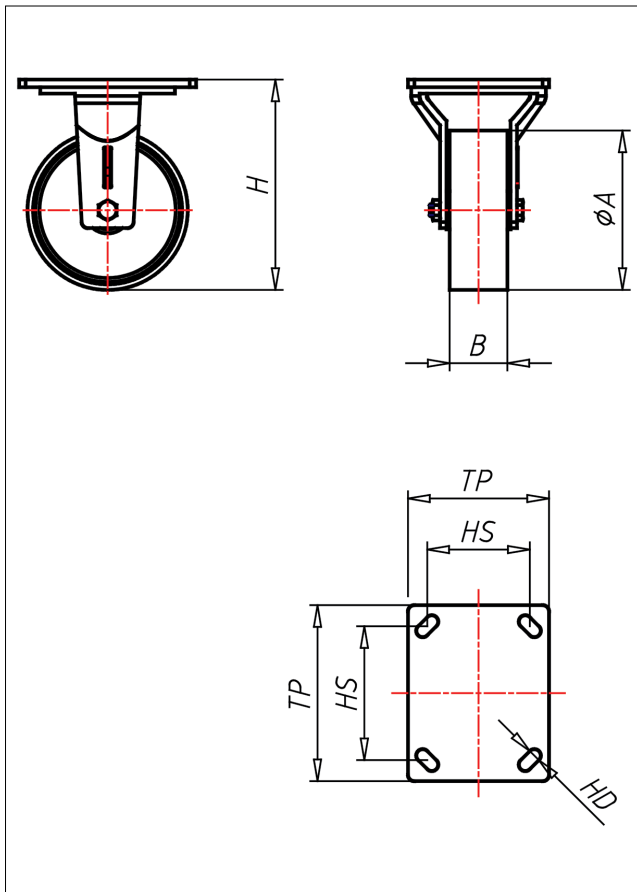

GTF-PK/P

Fixed castor



GT-P



LENKROLLE	RADFESTSTELLER	BOCKROLLE																				
<ul style="list-style-type: none"> • leichter Lauf auf glatten Böden • stoß- und schlagfest • hohe Abriebfestigkeit • leicht zu reinigen • sehr beständig gegen viele aggressive Medien Polyamid 6 - 1. Wahl → Seite 272	Schwerlastlenkgehäuse ohne Mittelbolzen mit gehärtetem Drehkranz und gehärteten Stahlkugeln, geschmiedet und getempert → Seite 42	AUSWAHLHILFE: <table border="1"> <tr> <td>leicht lenkend</td> <td>-</td> <td>+</td> <td>++</td> </tr> <tr> <td>verschleißarm</td> <td>x</td> <td></td> <td></td> </tr> <tr> <td>stoßfest</td> <td></td> <td></td> <td>x</td> </tr> <tr> <td>bodenschonend</td> <td></td> <td>x</td> <td></td> </tr> <tr> <td>witterungsbeständig</td> <td></td> <td></td> <td>x</td> </tr> </table>	leicht lenkend	-	+	++	verschleißarm	x			stoßfest			x	bodenschonend		x		witterungsbeständig			x
leicht lenkend	-	+	++																			
verschleißarm	x																					
stoßfest			x																			
bodenschonend		x																				
witterungsbeständig			x																			

Technische Details

ORDERNO (Article-number)	GTF 101 PK
WDAB (Wheel-Ø A x width B / mm)	100x37
LC (Load capacity / kg)	450
H (Overall height H / mm)	140
TP (Dimension of top plate / mm)	138x110
HS (Hole spacing / mm)	105x80
HD (Hole-Ø / mm)	10
WB (Wheel bearing)	Ball bearing