

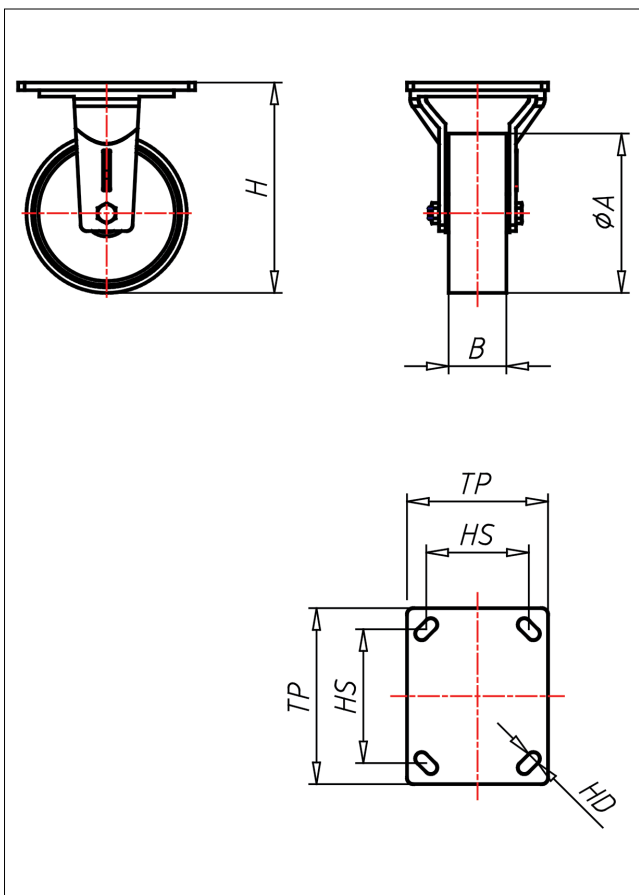

# GTF-PK/P

## Fixed castor



### GT-P



LENKROLLE	RADFESTSTELLER	BOCKROLLE																				
<ul style="list-style-type: none"> <li>• leichter Lauf auf glatten Böden</li> <li>• stoß- und schlagfest</li> <li>• hohe Abriebfestigkeit</li> <li>• leicht zu reinigen</li> <li>• sehr beständig gegen viele aggressive Medien</li> </ul> Polyamid 6 - 1. Wahl → Seite 272	<p>Schwerlastlenkgehäuse ohne Mittelbolzen mit gehärtetem Drehkranz und gehärteten Stahlkugeln, geschmiedet und getempert</p> → Seite 42	AUSWAHLHILFE: <table border="1"> <tr> <td>leicht lenkend</td> <td>-</td> <td>+</td> <td>++</td> </tr> <tr> <td>verschleißarm</td> <td>x</td> <td></td> <td></td> </tr> <tr> <td>stoßfest</td> <td></td> <td></td> <td>x</td> </tr> <tr> <td>bodenschonend</td> <td></td> <td>x</td> <td></td> </tr> <tr> <td>witterungsbeständig</td> <td></td> <td></td> <td>x</td> </tr> </table>	leicht lenkend	-	+	++	verschleißarm	x			stoßfest			x	bodenschonend		x		witterungsbeständig			x
leicht lenkend	-	+	++																			
verschleißarm	x																					
stoßfest			x																			
bodenschonend		x																				
witterungsbeständig			x																			

### Technische Details

<b>ORDERNO (Article-number)</b>	GTF 151 PK
<b>WDAB (Wheel-Ø A x width B / mm)</b>	150x48
<b>LC (Load capacity / kg)</b>	900
<b>H (Overall height H / mm)</b>	200
<b>TP (Dimension of top plate / mm)</b>	150x105
<b>HS (Hole spacing / mm)</b>	105x80
<b>HD (Hole-Ø / mm)</b>	13
<b>WB (Wheel bearing)</b>	Ball bearing