

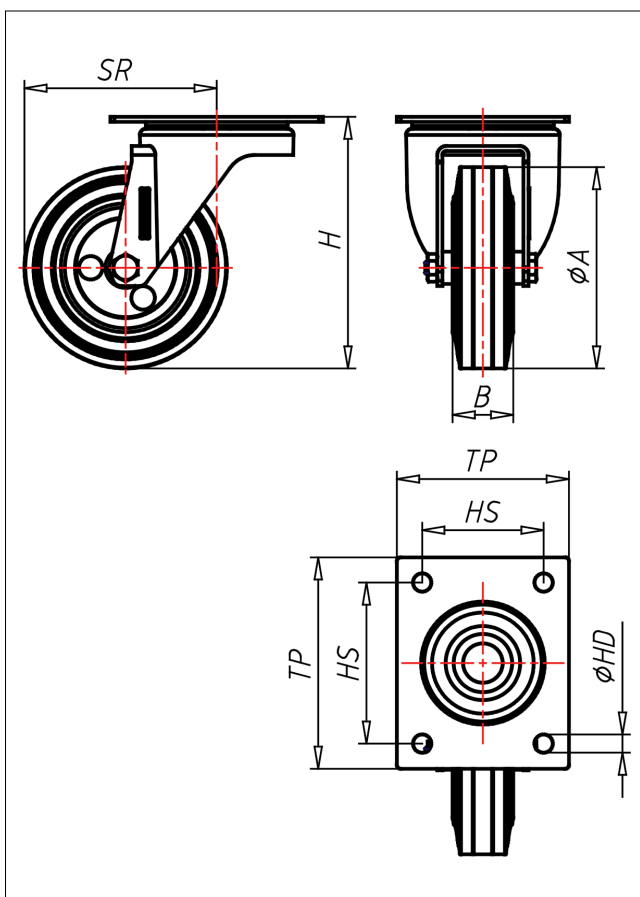

IN/INV-ELBX

Lenkrolle



IN-EL



LENKROLLE	LENKROLLE MIT TOTALFESTSTELLER	BOCKROLLE																		
<ul style="list-style-type: none"> • elektrisch leitfähig • Widerstand <math><10^{\circ}\Omega</math> • geräuscharmer Lauf • großer Fahrkomfort • beständig gegen verdünnte Säuren Vollgummi schwarz Felge aus Edelstahl → Seite 267	<ul style="list-style-type: none"> • zweifaches Kugellager - verschraubt, • Staubschutzring, • Radachse verschraubt - gesichert, • Edelstahl poliert → Seite 110	AUSWAHLHILFE: <table border="1"> <tr> <td>-</td> <td>+</td> <td>++</td> </tr> <tr> <td>leicht lenkend</td> <td>x</td> <td>x</td> </tr> <tr> <td>verschleißarm</td> <td>x</td> <td>x</td> </tr> <tr> <td>stoßfest</td> <td>x</td> <td>x</td> </tr> <tr> <td>bodenschonend</td> <td>x</td> <td>x</td> </tr> <tr> <td>witterungsbeständig</td> <td>x</td> <td>x</td> </tr> </table>	-	+	++	leicht lenkend	x	x	verschleißarm	x	x	stoßfest	x	x	bodenschonend	x	x	witterungsbeständig	x	x
-	+	++																		
leicht lenkend	x	x																		
verschleißarm	x	x																		
stoßfest	x	x																		
bodenschonend	x	x																		
witterungsbeständig	x	x																		

Technische Details

ORDERNO (Artikel-nummer)	IN 200 ELBX
WDAB (Rad-Ø A x Breite B / mm)	200x50
LC (Tragkraft / kg)	205
H (Bauhöhe H / mm)	230
TP (Plattengröße / mm)	135x110
HS (Lochabstand / mm)	105x80
HD (Loch-Ø / mm)	11
SR (Schwenkradius / mm)	160
WB (Radlager)	Rollenlager