

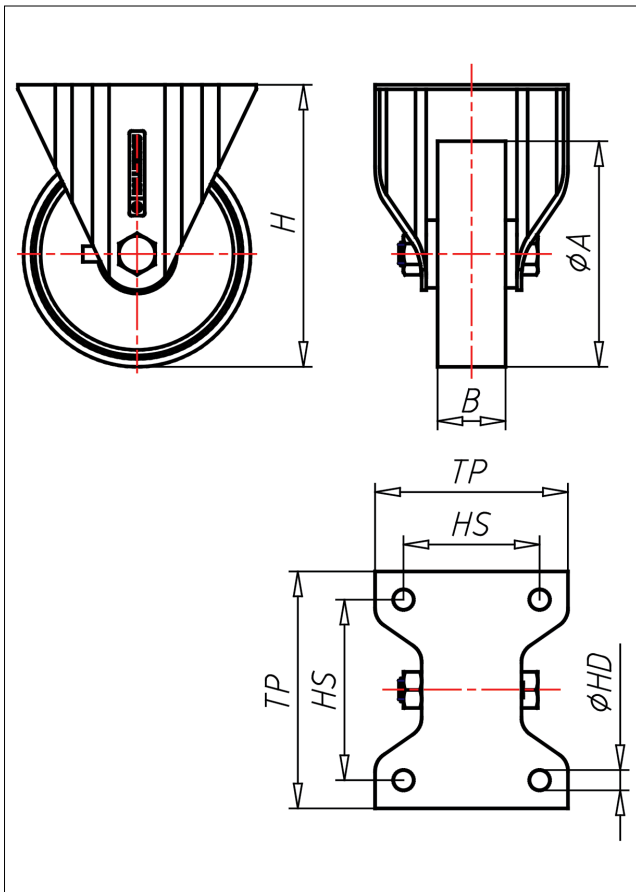

INF/INVF-PBX/P/PL

Bockrolle



IN-P



LENKROLLE	LENKROLLE MIT TOTALFESTSTELLER	BOCKROLLE																		
<ul style="list-style-type: none"> • leichter Lauf auf glatten Böden • stoß- und schlagfest • hohe Abriebfestigkeit • leicht zu reinigen • sehr beständig gegen viele aggressive Medien Polyamid 6 - 1. Wahl → Seite 272	 zweifaches Kugellager - verschraubt, Staubschutzring, Radachse verschraubt - gesichert, Edelstahl poliert → Seite 110	AUSWAHLHILFE: <table border="0"> <tr> <td>-</td><td>+</td><td>++</td></tr> <tr> <td>leicht lenkend</td><td>X</td><td>X</td></tr> <tr> <td>verschleißarm</td><td>○</td><td>X</td></tr> <tr> <td>stoßfest</td><td>X</td><td>X</td></tr> <tr> <td>bodenschonend</td><td>○</td><td>X</td></tr> <tr> <td>witterungsbeständig</td><td>○</td><td>X</td></tr> </table>	-	+	++	leicht lenkend	X	X	verschleißarm	○	X	stoßfest	X	X	bodenschonend	○	X	witterungsbeständig	○	X
-	+	++																		
leicht lenkend	X	X																		
verschleißarm	○	X																		
stoßfest	X	X																		
bodenschonend	○	X																		
witterungsbeständig	○	X																		

Technische Details

ORDERNO (Artikel-nummer)	INF 200 P
WDAB (Rad-Ø A x Breite B / mm)	200x50
LC (Tragkraft / kg)	250
H (Bauhöhe H / mm)	230
TP (Plattengröße / mm)	135x110
HS (Lochabstand / mm)	105x80
HD (Loch-Ø / mm)	11
WB (Radlager)	Polyamid-Gleitlager