

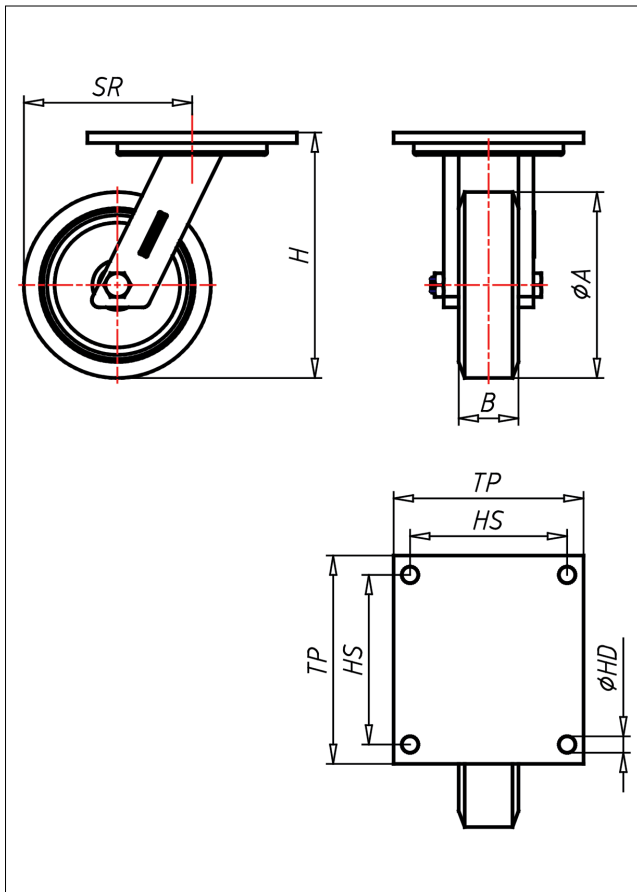

INSS-A

Lenkrolle

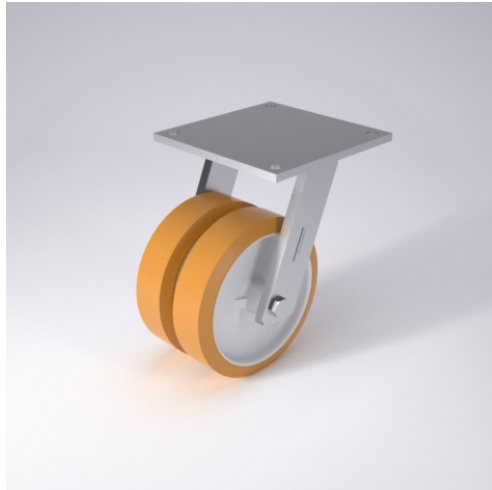

INSS-A



LENKROLLE	LENKROLLE MIT TOTALFESTSTELLER	BOCKROLLE																				
<ul style="list-style-type: none">geräuscharmer Laufgeringer Rollwiderstandabrieb- und reißfesthohe Stoßfestigkeitleichte Reinigungsehr beständig gegen viele aggressive Medien <p>Guss-Polyurethan Felge Polyamid 6 → Seite 252</p>	<p>zweifaches Kugellager mit Dauerfettfüllung. Edelstahlschweißkonstruktion ohne Mittelbolzen, Radachse verschraubt → Seite 110</p>	<p>AUSWAHLHILFE:</p> <table border="1"><tr><td>leicht lenkend</td><td>+</td><td>+</td><td>+</td></tr><tr><td>verschleißarm</td><td>+</td><td>+</td><td>+</td></tr><tr><td>stoßfest</td><td>+</td><td>+</td><td>+</td></tr><tr><td>bodenschonend</td><td>+</td><td>+</td><td>+</td></tr><tr><td>witterungsbeständig</td><td>+</td><td>+</td><td>+</td></tr></table>	leicht lenkend	+	+	+	verschleißarm	+	+	+	stoßfest	+	+	+	bodenschonend	+	+	+	witterungsbeständig	+	+	+
leicht lenkend	+	+	+																			
verschleißarm	+	+	+																			
stoßfest	+	+	+																			
bodenschonend	+	+	+																			
witterungsbeständig	+	+	+																			

Technische Details

ORDERNO (Artikelnummer)	INSS 200 A
WDAB (Rad-Ø A x Breite B / mm)	200x50
LC (Tragkraft / kg)	600
H (Bauhöhe H / mm)	241
TP (Plattengröße / mm)	150x150
HS (Lochabstand / mm)	125x125
HD (Loch-Ø / mm)	11
SR (Schwenkradius / mm)	165
WB (Radlager)	Polyamid-Gleitlager