

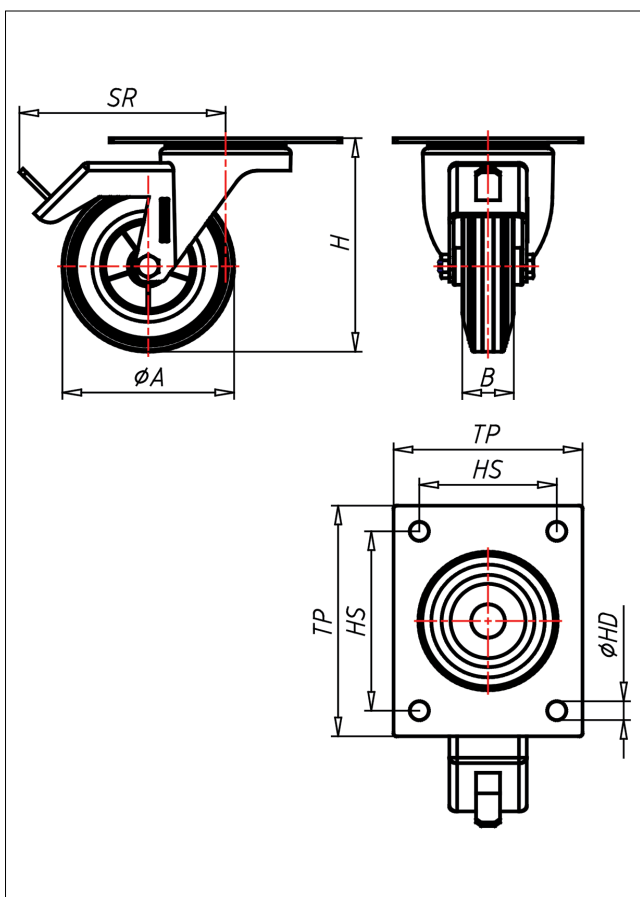

INT/INVT-DGBX/DG

Lenkrolle mit Totalfeststeller



IN-DG



LENKROLLE	LENKROLLE MIT TOTALFESTSTELLER	BOCKROLLE																				
<ul style="list-style-type: none"> • spurfrei - bodenschonend • hoher Fahrkomfort • sehr lauffähig • geringer Rollwiderstand • abriebfest <p>ELASTIK-Vollgummi Felge Kunststoff → Seite 202</p>	<p>zweifaches Kugellager - verschraubt, Staubschützring, Radachse verschraubt - gesichert, Edelstahl poliert</p> <p>→ Seite 110</p>	<p>AUSWAHLHILFE:</p> <table border="0"> <tr> <td>leicht lenkend</td> <td>-</td> <td>+</td> <td>++</td> </tr> <tr> <td>erschleißarm</td> <td>X</td> <td></td> <td></td> </tr> <tr> <td>stoßfest</td> <td>X</td> <td></td> <td></td> </tr> <tr> <td>bodenschonend</td> <td></td> <td>X</td> <td></td> </tr> <tr> <td>witterungsbeständig</td> <td></td> <td>X</td> <td></td> </tr> </table>	leicht lenkend	-	+	++	erschleißarm	X			stoßfest	X			bodenschonend		X		witterungsbeständig		X	
leicht lenkend	-	+	++																			
erschleißarm	X																					
stoßfest	X																					
bodenschonend		X																				
witterungsbeständig		X																				

Technische Details

ORDERNO (Artikel-nummer)	INT 150 DGBX
WDAB (Rad-Ø A x Breite B / mm)	150x40
LC (Tragkraft / kg)	150
H (Bauhöhe H / mm)	180
TP (Plattengröße / mm)	135x110
HS (Lochabstand / mm)	105x80
HD (Loch-Ø / mm)	11
SR (Schwenkradius / mm)	150
WB (Radlager)	Rollenlager