

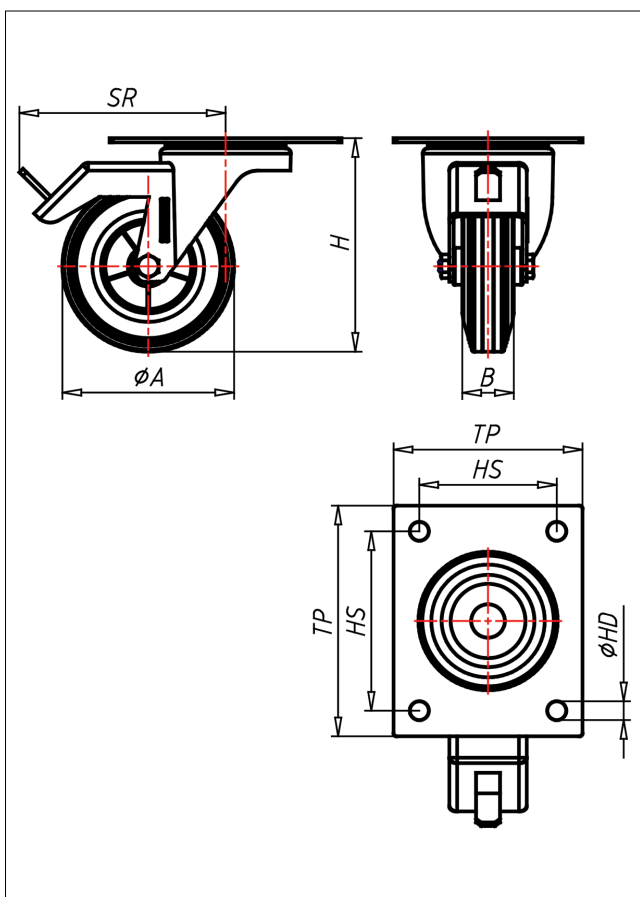

INT/INVT-DGBX/DG

Lenkrolle mit Totalfeststeller



IN-DG



LENKROLLE	LENKROLLE MIT TOTALFESTSTELLER	BOCKROLLE																				
<ul style="list-style-type: none"> • spurfrei - bodenschonend • hoher Fahrkomfort • sehr lauffähig • geringer Rollwiderstand • abriebfest ELASTIK-Vollgummi Felge Kunststoff → Seite 202	zweifaches Kugellager - verschraubt, Staubschutzring, Radachse verschraubt - gesichert, Edelstahl poliert → Seite 110	AUSWAHLHILFE: <table border="0"> <tr> <td>leicht lenkend</td> <td>+</td> <td>+</td> <td>+</td> </tr> <tr> <td>verschleißarm</td> <td>x</td> <td>x</td> <td>x</td> </tr> <tr> <td>stoßfest</td> <td>x</td> <td>x</td> <td>x</td> </tr> <tr> <td>bodenschonend</td> <td>+</td> <td>+</td> <td>+</td> </tr> <tr> <td>witterungsbeständig</td> <td>x</td> <td>x</td> <td>x</td> </tr> </table>	leicht lenkend	+	+	+	verschleißarm	x	x	x	stoßfest	x	x	x	bodenschonend	+	+	+	witterungsbeständig	x	x	x
leicht lenkend	+	+	+																			
verschleißarm	x	x	x																			
stoßfest	x	x	x																			
bodenschonend	+	+	+																			
witterungsbeständig	x	x	x																			

Technische Details

ORDERNO (Artikel-nummer)	INT 160 DGBX
WDAB (Rad-Ø A x Breite B / mm)	160x40
LC (Tragkraft / kg)	160
H (Bauhöhe H / mm)	185
TP (Plattengröße / mm)	135x110
HS (Lochabstand / mm)	105x80
HD (Loch-Ø / mm)	11
SR (Schwenkradius / mm)	150
WB (Radlager)	Rollenlager