

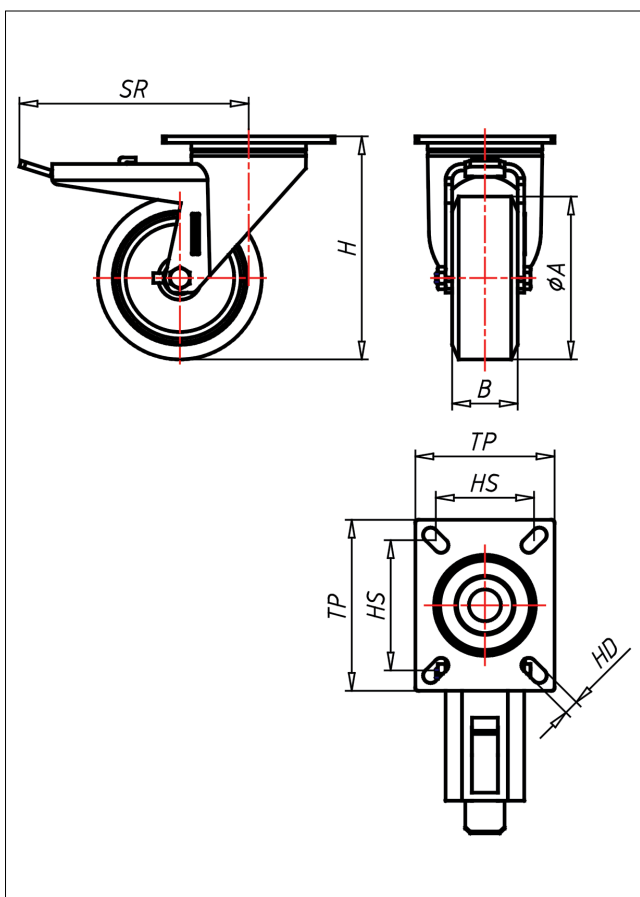

IPT/IPST-ABX/A

Lenkrolle mit Totalfeststeller



IP-A



LENKROLLE	LENKROLLE MIT TOTALFESTSTELLER	BOCKROLLE																		
<ul style="list-style-type: none"> geräuscharmer Lauf geringer Rollwiderstand abrieb- und reißfest hohe Stoßfestigkeit leichte Reinigung sehr beständig gegen viele aggressive Medien <p>Guss-Polyurethan Felge Polyamid 6 → Seite 252</p>	 Gehäuse aus Edelstahl AISI 304, eingewerbter Zentralzapfen aus Edelstahl AISI 303, verschraubt, Wasser- und Staubabdichtungsring → Seite 110	AUSWAHLHILFE: <table border="0"> <tr> <td>-</td><td>+</td><td>++</td></tr> <tr> <td>leicht lenkend</td><td>○</td><td>✗</td></tr> <tr> <td>verschleißarm</td><td>○</td><td>✗</td></tr> <tr> <td>stoßfest</td><td>○</td><td>✗</td></tr> <tr> <td>bodenschonend</td><td>○</td><td>✗</td></tr> <tr> <td>witterungsbeständig</td><td>○</td><td>✗</td></tr> </table>	-	+	++	leicht lenkend	○	✗	verschleißarm	○	✗	stoßfest	○	✗	bodenschonend	○	✗	witterungsbeständig	○	✗
-	+	++																		
leicht lenkend	○	✗																		
verschleißarm	○	✗																		
stoßfest	○	✗																		
bodenschonend	○	✗																		
witterungsbeständig	○	✗																		

Technische Details

ORDERNO (Artikel-nummer)	IPT 150 A
WDAB (Rad-Ø A x Breite B / mm)	150x40
LC (Tragkraft / kg)	370
H (Bauhöhe H / mm)	192
TP (Plattengröße / mm)	135x110
HS (Lochabstand / mm)	105x80
HD (Loch-Ø / mm)	11
SR (Schwenkradius / mm)	170
WB (Radlager)	Polyamid-Gleitlager