

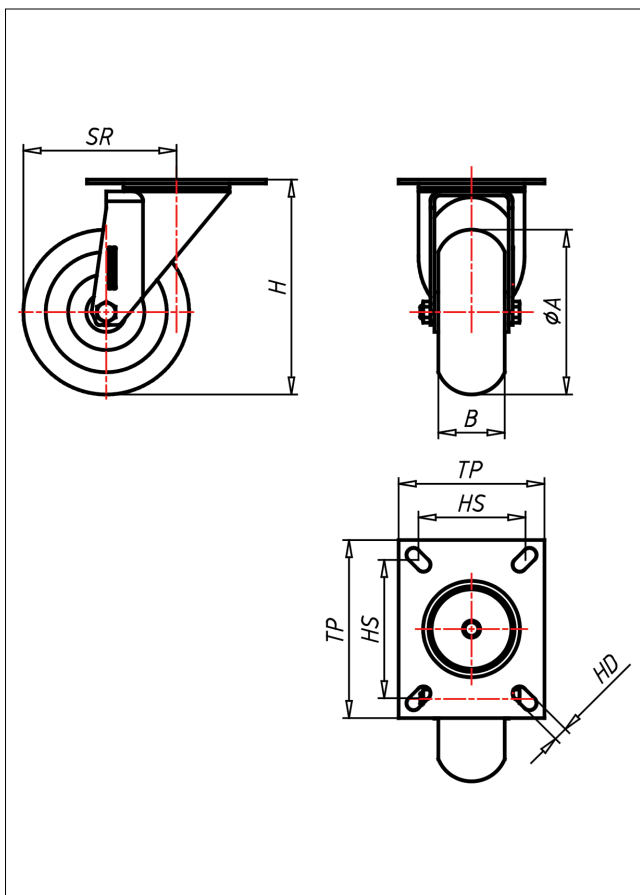

KD-TLBAK

Lenkrolle

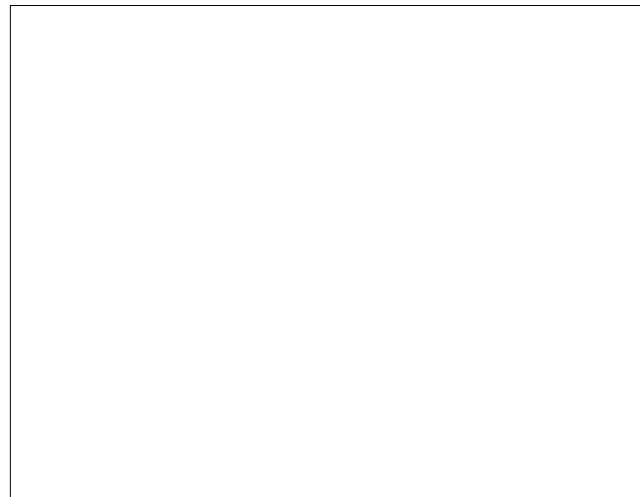

KD-TLBA



NEU!

Lenkrolle Swivel Castor	Lenkrolle mit Totalfeststeller Swivel Castor with total lock	Bockrolle Fixed Castor																									
<ul style="list-style-type: none"> sehr geräuscharmer Lauf sehr geringer Rollwiderstand sehr drehfreudig abrieb- und reißfest sehr beständig gegen viele aggressive Medien <p>Guss-Polyurethane 95 ± 3 Shore A ballig Felge: Spritzguss-Aluminium-Lagerung → Seite/Page 331</p>	<p>Laufkugeln gehärtet, Kugelbahnen gepresst, starker Zentralzapfen verschraubt - gedichtet - gesichert Staubschutzring, verzinkt</p> <p>→ Seite/Page 112</p>	<p>Auswahlhilfe Selection Criteria</p> <table border="1"> <tr> <td>leicht lenkbar/swivels easily</td> <td><input type="radio"/></td> <td><input type="radio"/></td> <td><input checked="" type="radio"/></td> <td><input type="radio"/></td> </tr> <tr> <td>verschleißarm/wear resistant</td> <td><input type="radio"/></td> <td><input type="radio"/></td> <td><input checked="" type="radio"/></td> <td><input type="radio"/></td> </tr> <tr> <td>stößelstark/shock proof</td> <td><input type="radio"/></td> <td><input type="radio"/></td> <td><input checked="" type="radio"/></td> <td><input type="radio"/></td> </tr> <tr> <td>bodenschonend/floor protection</td> <td><input type="radio"/></td> <td><input type="radio"/></td> <td><input checked="" type="radio"/></td> <td><input type="radio"/></td> </tr> <tr> <td>witterungsbeständig/weather proof</td> <td><input type="radio"/></td> <td><input type="radio"/></td> <td><input checked="" type="radio"/></td> <td><input type="radio"/></td> </tr> </table>	leicht lenkbar/swivels easily	<input type="radio"/>	<input type="radio"/>	<input checked="" type="radio"/>	<input type="radio"/>	verschleißarm/wear resistant	<input type="radio"/>	<input type="radio"/>	<input checked="" type="radio"/>	<input type="radio"/>	stößelstark/shock proof	<input type="radio"/>	<input type="radio"/>	<input checked="" type="radio"/>	<input type="radio"/>	bodenschonend/floor protection	<input type="radio"/>	<input type="radio"/>	<input checked="" type="radio"/>	<input type="radio"/>	witterungsbeständig/weather proof	<input type="radio"/>	<input type="radio"/>	<input checked="" type="radio"/>	<input type="radio"/>
leicht lenkbar/swivels easily	<input type="radio"/>	<input type="radio"/>	<input checked="" type="radio"/>	<input type="radio"/>																							
verschleißarm/wear resistant	<input type="radio"/>	<input type="radio"/>	<input checked="" type="radio"/>	<input type="radio"/>																							
stößelstark/shock proof	<input type="radio"/>	<input type="radio"/>	<input checked="" type="radio"/>	<input type="radio"/>																							
bodenschonend/floor protection	<input type="radio"/>	<input type="radio"/>	<input checked="" type="radio"/>	<input type="radio"/>																							
witterungsbeständig/weather proof	<input type="radio"/>	<input type="radio"/>	<input checked="" type="radio"/>	<input type="radio"/>																							

Technische Details

ORDERNO (Artikel-nummer)	KD 150 TLBAK
WDAB (Rad-Ø A x Breite B / mm)	150x50
LC (Tragkraft / kg)	400
H (Bauhöhe H / mm)	194
TP (Plattengröße / mm)	135x110
HS (Lochabstand / mm)	105x80
HD (Loch-Ø / mm)	12.5
SR (Schwenkradius / mm)	125
WB (Radlager)	Kugellager