

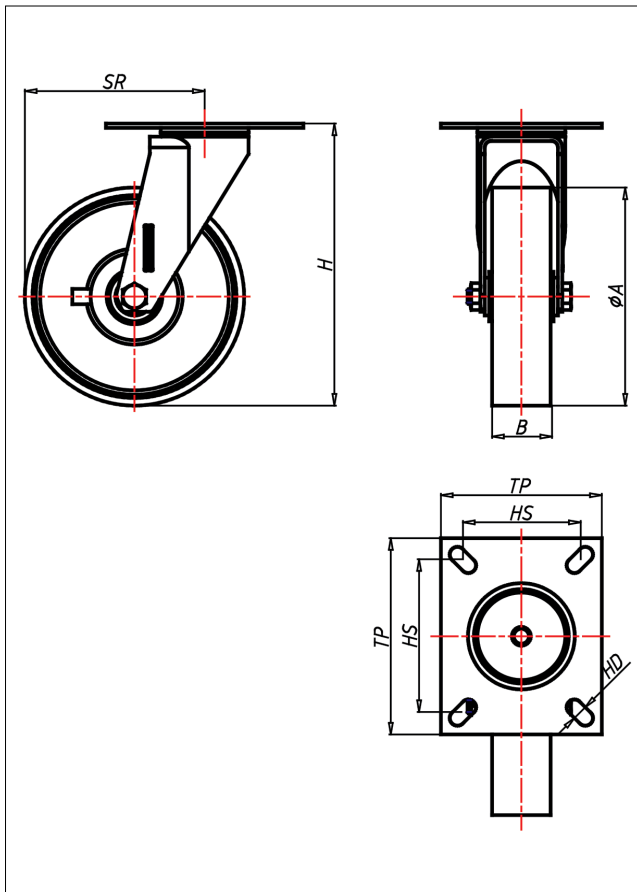

KD/KS-PK/PB/P

Lenkrolle



KD-P



LENKROLLE	LENKROLLE MIT TOTALFESTSTELLER	BOCKROLLE																									
 <ul style="list-style-type: none"> • leichter Lauf auf glatten Böden • stoß- und schlagfest • hohe Abriebfestigkeit • leicht zu reinigen • sehr beständig gegen viele aggressive Medien <p>Polyamid 6 - 1. Wahl</p> <p>→ Seite 272</p> 	 <p>Laufkugeln gehärtet, Kugelbahnen gepresst, starker Zentralzapfen verschraubt - gedichtet - gesichert Staubschutzring, verzinkt</p> <p>→ Seite 62</p>	 <p>AUSWAHLHILFE:</p> <table border="0"> <tr> <td>leicht lenkend</td> <td>+</td> <td>-</td> <td>+</td> <td>+</td> </tr> <tr> <td>verschleißarm</td> <td>+</td> <td>-</td> <td>x</td> <td>x</td> </tr> <tr> <td>stoßfest</td> <td>+</td> <td>-</td> <td>x</td> <td>x</td> </tr> <tr> <td>bodenschonend</td> <td>+</td> <td>-</td> <td>x</td> <td>x</td> </tr> <tr> <td>witterungsbeständig</td> <td>+</td> <td>-</td> <td>x</td> <td>x</td> </tr> </table>	leicht lenkend	+	-	+	+	verschleißarm	+	-	x	x	stoßfest	+	-	x	x	bodenschonend	+	-	x	x	witterungsbeständig	+	-	x	x
leicht lenkend	+	-	+	+																							
verschleißarm	+	-	x	x																							
stoßfest	+	-	x	x																							
bodenschonend	+	-	x	x																							
witterungsbeständig	+	-	x	x																							

Technische Details

ORDERNO (Artikel-nummer)	KD 200 PK
WDAB (Rad-Ø A x Breite B / mm)	200x50
LC (Tragkraft / kg)	450
H (Bauhöhe H / mm)	249
TP (Plattengröße / mm)	135x110
HS (Lochabstand / mm)	105x80
HD (Loch-Ø / mm)	12.5
SR (Schwenkradius / mm)	165
WB (Radlager)	Kugellager