

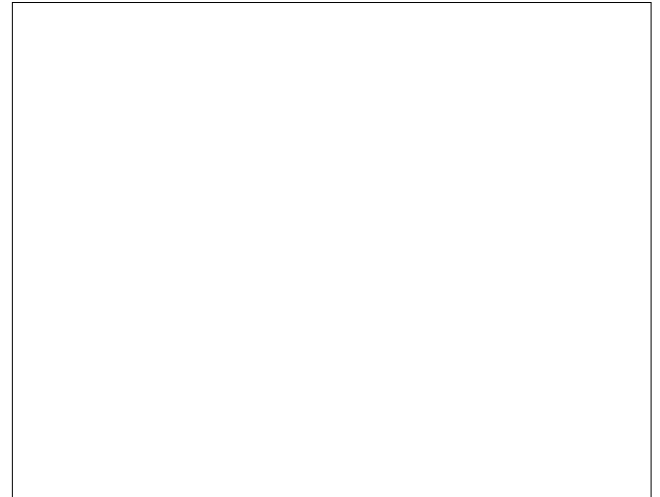

# KDF/KSF- EK/EB/LEK/LEB Bockrolle

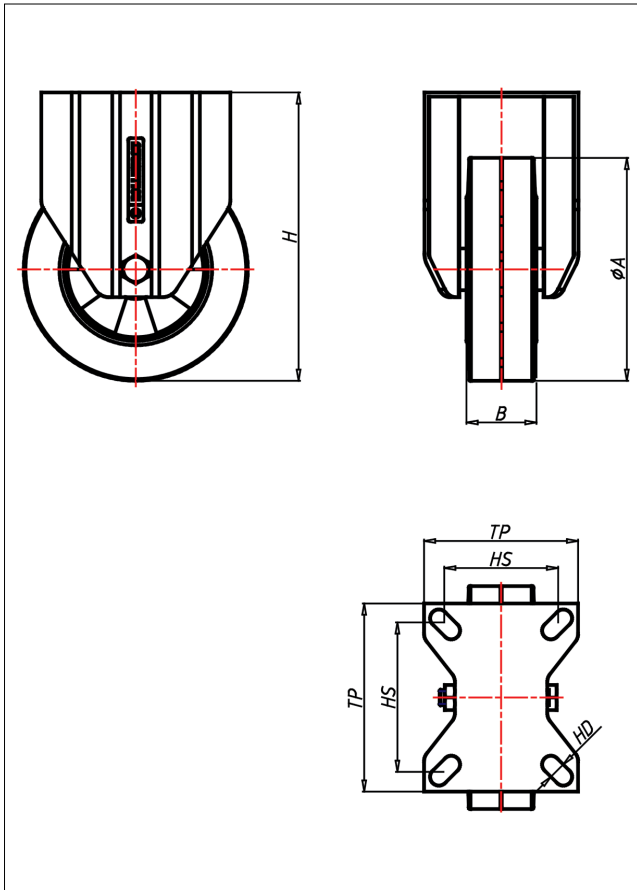

## KD-E



| LENKROLLE   | LENKROLLE MIT TOTALFESTSTELLER   | BOCKROLLE   |                |   |   |   |   |   |   |   |   |   |               |   |   |   |   |   |   |   |   |   |          |   |   |   |   |   |   |   |   |   |               |   |   |   |   |   |   |   |   |   |                     |   |   |   |   |   |   |   |   |   |
|---|--|---|----------------|---|---|---|---|---|---|---|---|---|---------------|---|---|---|---|---|---|---|---|---|----------|---|---|---|---|---|---|---|---|---|---------------|---|---|---|---|---|---|---|---|---|---------------------|---|---|---|---|---|---|---|---|---|
|  <ul style="list-style-type: none"> <li>• hoher Fahrkomfort</li> <li>• sehr laufuhig</li> <li>• geringer Rollwiderstand</li> <li>• abriebfest</li> <li>• spurfrei in grau</li> </ul> <p>ELASTIK-Vollgummi<br/>Felge Spritzguss-<br/>Aluminiumlegierung<br/>→ Seite 233</p>  |   <p>Laufkugeln gehärtet, Kugelbahnen<br/>gespresst, starker Zentralzapfen<br/>verschraubt - gedichtet - gesichert<br/>Staubschutzring, verzinkt</p> <p>→ Seite 62</p> |  <p>AUSWAHLHILFE:</p> <table border="1"> <tr> <td>leicht lenkend</td> <td>+</td> <td>+</td> <td>+</td> <td>+</td> <td>+</td> <td>+</td> <td>+</td> <td>+</td> <td>+</td> </tr> <tr> <td>verschleißarm</td> <td>-</td> <td>-</td> <td>-</td> <td>-</td> <td>-</td> <td>-</td> <td>-</td> <td>-</td> <td>-</td> </tr> <tr> <td>stoßfest</td> <td>+</td> <td>+</td> <td>+</td> <td>+</td> <td>+</td> <td>+</td> <td>+</td> <td>+</td> <td>+</td> </tr> <tr> <td>bodenschonend</td> <td>-</td> <td>-</td> <td>-</td> <td>-</td> <td>-</td> <td>-</td> <td>-</td> <td>-</td> <td>-</td> </tr> <tr> <td>witterungsbeständig</td> <td>+</td> <td>+</td> <td>+</td> <td>+</td> <td>+</td> <td>+</td> <td>+</td> <td>+</td> <td>+</td> </tr> </table> | leicht lenkend | + | + | + | + | + | + | + | + | + | verschleißarm | - | - | - | - | - | - | - | - | - | stoßfest | + | + | + | + | + | + | + | + | + | bodenschonend | - | - | - | - | - | - | - | - | - | witterungsbeständig | + | + | + | + | + | + | + | + | + |
| leicht lenkend  | +  | +   | +              | + | + | + | + | + | + |   |   |   |               |   |   |   |   |   |   |   |   |   |          |   |   |   |   |   |   |   |   |   |               |   |   |   |   |   |   |   |   |   |                     |   |   |   |   |   |   |   |   |   |
| verschleißarm   | -  | -   | -              | - | - | - | - | - | - |   |   |   |               |   |   |   |   |   |   |   |   |   |          |   |   |   |   |   |   |   |   |   |               |   |   |   |   |   |   |   |   |   |                     |   |   |   |   |   |   |   |   |   |
| stoßfest  | +  | +   | +              | + | + | + | + | + | + |   |   |   |               |   |   |   |   |   |   |   |   |   |          |   |   |   |   |   |   |   |   |   |               |   |   |   |   |   |   |   |   |   |                     |   |   |   |   |   |   |   |   |   |
| bodenschonend   | -  | -   | -              | - | - | - | - | - | - |   |   |   |               |   |   |   |   |   |   |   |   |   |          |   |   |   |   |   |   |   |   |   |               |   |   |   |   |   |   |   |   |   |                     |   |   |   |   |   |   |   |   |   |
| witterungsbeständig   | +  | +   | +              | + | + | + | + | + | + |   |   |   |               |   |   |   |   |   |   |   |   |   |          |   |   |   |   |   |   |   |   |   |               |   |   |   |   |   |   |   |   |   |                     |   |   |   |   |   |   |   |   |   |

## Technische Details

|                                       |              |
|---------------------------------------|--------------|
| <b>ORDERNO (Artikel-nummer)</b>       | KDF 100 EK   |
| <b>WDAB (Rad-Ø A x Breite B / mm)</b> | 100x40       |
| <b>LC (Tragkraft / kg)</b>            | 150          |
| <b>H (Bauhöhe H / mm)</b>             | 137          |
| <b>TP (Plattengröße / mm)</b>         | 105x85       |
| <b>HS (Lochabstand / mm)</b>          | 80x60        |
| <b>HD (Loch-Ø / mm)</b>               | 8.5          |
| <b>WB (Radlager)</b>                  | Ball bearing |