

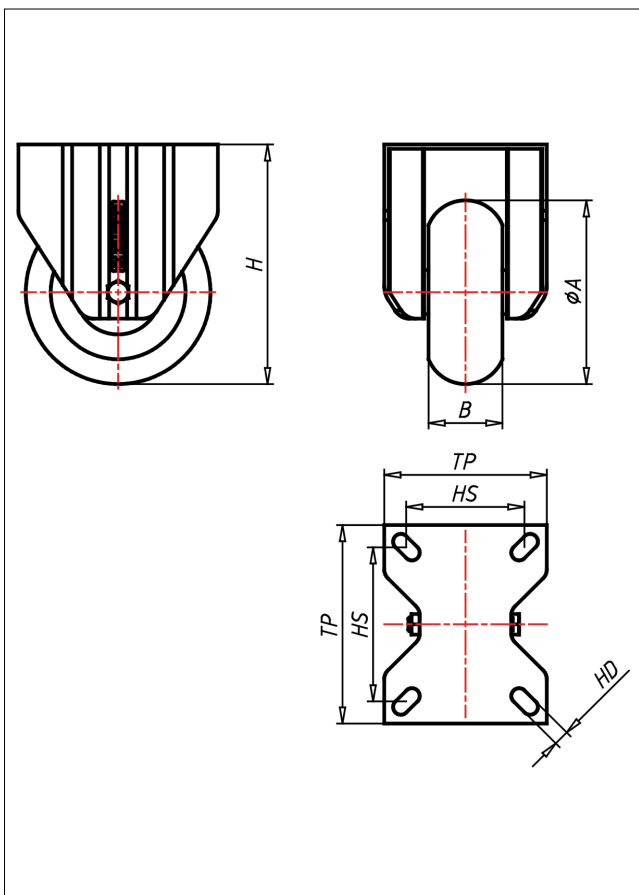

KDF-TLBAK

Bockrolle

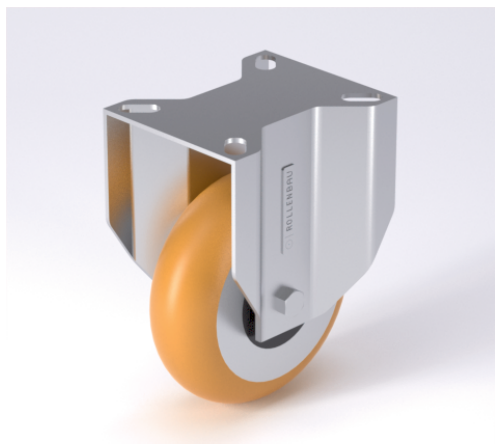

KD-TLBA



Lenkrolle Swivel Castor	Lenkrolle mit Totalfeststeller Swivel Castor with total lock	Bockrolle Fixed Castor																				
<p>NEU!</p> <ul style="list-style-type: none"> sehr geräuscharmer Lauf sehr geringer Rollwiderstand sehr drehfreudig abrieb- und rollfest sehr beständig gegen viele aggressive Medien <p>Guss-Polyurethane 95 ± 3 Shore A ballig Felle: Spritzguss-Aluminium-Lagerung → Seite/Page 331</p>	<p>Laufkugeln gehärtet, Kugelbahnen gepresst, starker Zentralzapfen verschleiß- und gedichtet - geschützt Staubschutzring, verzinkt</p> <p>→ Seite/Page 112</p>	<p>Auswahlhilfe Selection Criteria</p> <table border="1"> <tr> <td>leicht lenkbar/swivels easily</td> <td><input type="checkbox"/></td> <td><input type="checkbox"/></td> <td><input type="checkbox"/></td> </tr> <tr> <td>verschleißarm/wear resistant</td> <td><input type="checkbox"/></td> <td><input type="checkbox"/></td> <td><input type="checkbox"/></td> </tr> <tr> <td>staubfest/dust proof</td> <td><input type="checkbox"/></td> <td><input type="checkbox"/></td> <td><input type="checkbox"/></td> </tr> <tr> <td>bodenschonend/floor protection</td> <td><input type="checkbox"/></td> <td><input type="checkbox"/></td> <td><input type="checkbox"/></td> </tr> <tr> <td>witterungsbeständig/weather proof</td> <td><input type="checkbox"/></td> <td><input type="checkbox"/></td> <td><input type="checkbox"/></td> </tr> </table>	leicht lenkbar/swivels easily	<input type="checkbox"/>	<input type="checkbox"/>	<input type="checkbox"/>	verschleißarm/wear resistant	<input type="checkbox"/>	<input type="checkbox"/>	<input type="checkbox"/>	staubfest/dust proof	<input type="checkbox"/>	<input type="checkbox"/>	<input type="checkbox"/>	bodenschonend/floor protection	<input type="checkbox"/>	<input type="checkbox"/>	<input type="checkbox"/>	witterungsbeständig/weather proof	<input type="checkbox"/>	<input type="checkbox"/>	<input type="checkbox"/>
leicht lenkbar/swivels easily	<input type="checkbox"/>	<input type="checkbox"/>	<input type="checkbox"/>																			
verschleißarm/wear resistant	<input type="checkbox"/>	<input type="checkbox"/>	<input type="checkbox"/>																			
staubfest/dust proof	<input type="checkbox"/>	<input type="checkbox"/>	<input type="checkbox"/>																			
bodenschonend/floor protection	<input type="checkbox"/>	<input type="checkbox"/>	<input type="checkbox"/>																			
witterungsbeständig/weather proof	<input type="checkbox"/>	<input type="checkbox"/>	<input type="checkbox"/>																			

Technische Details

ORDERNO (Artikel-nummer)	KDF 100 TLBAK
WDAB (Rad-Ø A x Breite B / mm)	100x50
LC (Tragkraft / kg)	250
H (Bauhöhe H / mm)	137
TP (Plattengröße / mm)	105x85
HS (Lochabstand / mm)	80x60
HD (Loch-Ø / mm)	8.5
SR (Schwenkradius / mm)	92
WB (Radlager)	Kugellager