

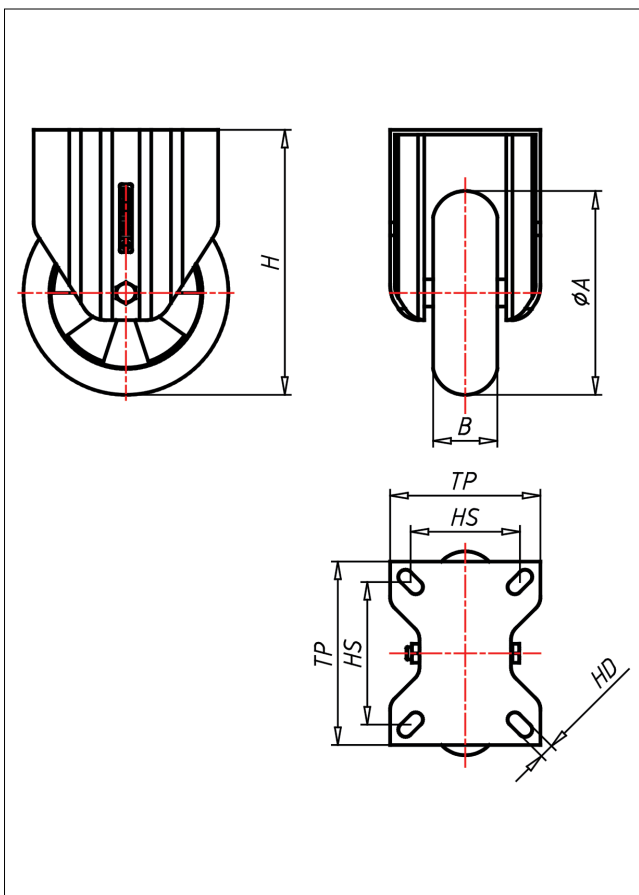

KDF/KSF-EGBAK

Bockrolle

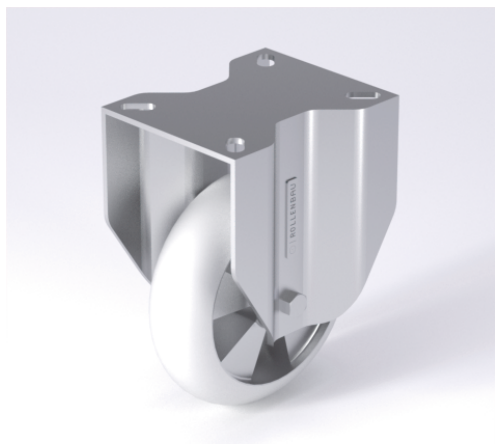

KD-EGBA



NEU!

Lenkrolle Swivel Castor	Lenkrolle mit Totalfeststeller Swivel Castor with total lock	Bockrolle Fixed Castor
<ul style="list-style-type: none"> sehr geräuscharmer Lauf sehr geringer Rollwiderstand abriebfest korrosionsbeständig Alternative zu Luftreifen SPURSTREIF 	<ul style="list-style-type: none"> Laufkugeln gehärtet, Kugelbahnen gepresst, starker Zentralzapfen verschraubt - gedichtet - gesichert Staubschutzring, verzinkt 	<ul style="list-style-type: none"> Auswahlhilfe Selection Criteria leicht lenkbar/swivels easily verschleißarm/wear resistant staubfest/dust proof bodenschonend/floor protective witterungsbeständig/weather proof
<ul style="list-style-type: none"> Elastik-Vollgummiläufen 55 ± 3 Shore A ballig Felge aus Spritzguss-Aluminium-Legierung → Seite/Page 345 	<ul style="list-style-type: none"> → Seite/Page 112 	

Technische Details

ORDERNO (Artikel-nummer)	KDF 250 EGBAK
WDAB (Rad-Ø A x Breite B / mm)	250x50
LC (Tragkraft / kg)	450
H (Bauhöhe H / mm)	304
TP (Plattengröße / mm)	135x110
HS (Lochabstand / mm)	105x80
HD (Loch-Ø / mm)	12.5
SR (Schwenkradius / mm)	194
WB (Radlager)	Kugellager