

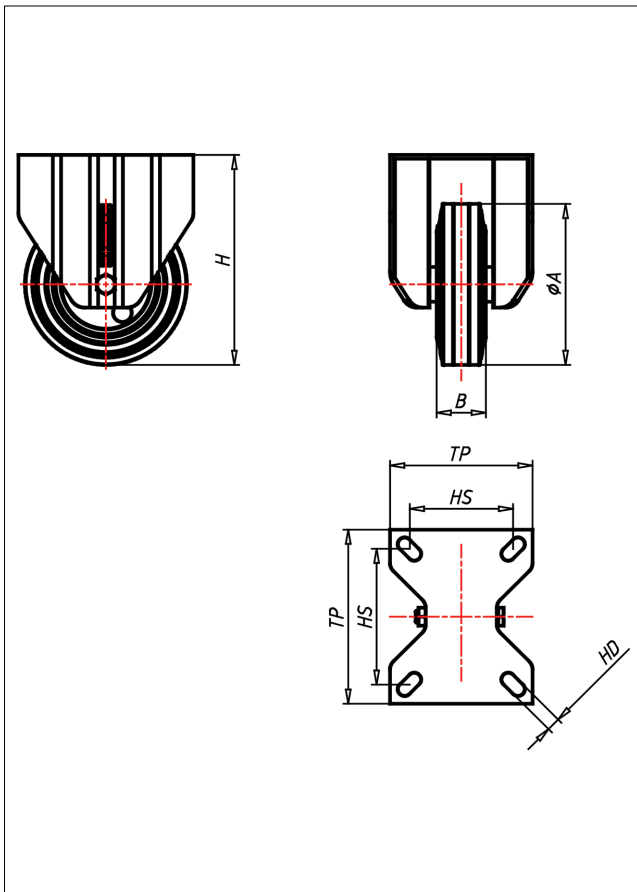

KDF-ELB

Bockrolle

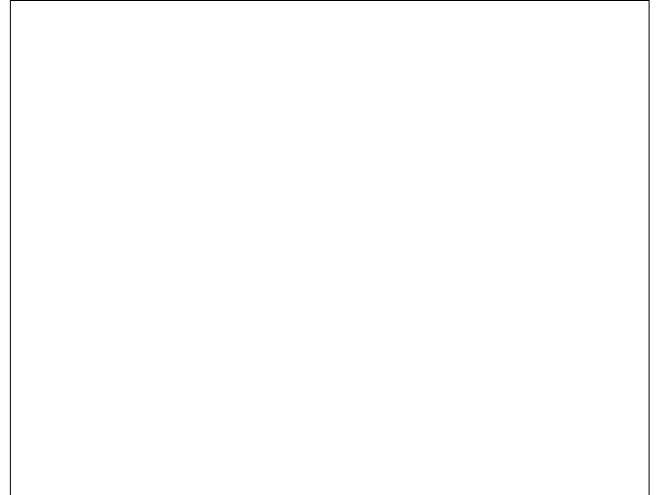
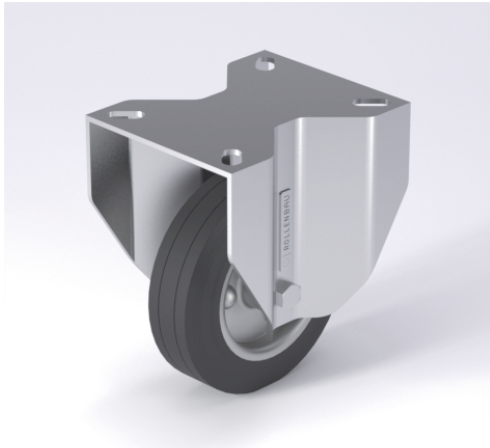

KD-EL



NEU!

Lenkrolle Swivel Castor	Lenkrolle mit Totfeststeller Swivel Castor with total lock	Bockrolle Fixed Castor
<ul style="list-style-type: none"> elektrisch leitfähig Widerstand <math><10^3\Omega</math> geräuscharmer Lauf großer Fahrkomfort beständig gegen verdünnte Säuren 	<ul style="list-style-type: none"> Laufkugeln gehärtet, Kugelbahnen gepresst, starker Zentralzapfen verschraubt - gedichtet - gesichert Staubschutzring, verzinkt 	<ul style="list-style-type: none"> Auswahlhilfe Selection Criteria leicht lenkend/swivels easily verschleißarm/wear resistant staubdicht/dustproof bodenschonend/floor protective witterungsbeständig/weather proof
<ul style="list-style-type: none"> Vollgummi schwarz Flange Stahlblech verzinkt → Seite/Page 355 	→ Seite/Page 112	

Technische Details

ORDERNO (Artikel-nummer)	KDF 80 ELB
WDAB (Rad-Ø A x Breite B / mm)	80x25
LC (Tragkraft / kg)	50
H (Bauhöhe H / mm)	128
TP (Plattengröße / mm)	105x85
HS (Lochabstand / mm)	80x60
HD (Loch-Ø / mm)	8.5
SR (Schwenkradius / mm)	83
WB (Radlager)	Rollenlager