

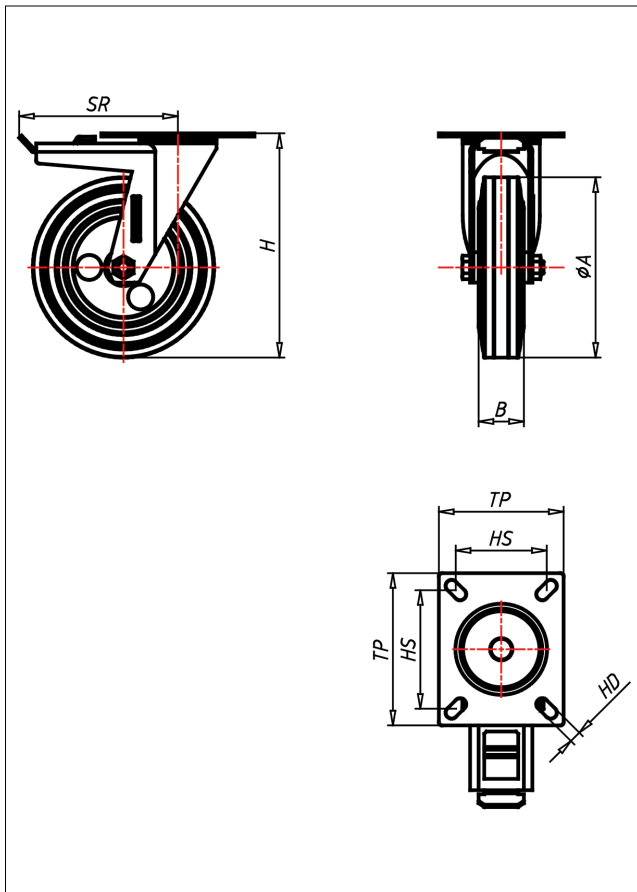

KDT-ELB

Lenkrolle mit Totalfeststeller



KD-EL



NEU!

Lenkrolle Swivel Castor	Lenkrolle mit Totalfeststeller Swivel Castor with total lock	Blockrolle Fixed Castor
<ul style="list-style-type: none"> ● elektrisch leitfähig ● Widerstand <math><10^{-3}</math> ● geräuscharmer Lauf ● großer Fahrkomfort ● beständig gegen verdünnte Säuren 	<ul style="list-style-type: none"> ● Laufkugeln gehärtet, Kugelbahnen gepresst, starker Zentralzapfen ● verschraubt - gedichtet - gesichert ● Staubschutzring, verzinkt 	<ul style="list-style-type: none"> ● Auswahlhilfe ● Selection Criteria ● leicht lenkend/swivels easily ● verschleißarm/wear resistant ● staubdicht/dust proof ● bodenschonend/floor protective ● witterungsbeständig/weather proof

→ Seite/Page 112

Technische Details

ORDERNO (Artikel-nummer)	KDT 100 ELB
WDAB (Rad-Ø A x Breite B / mm)	100x30
LC (Tragkraft / kg)	70
H (Bauhöhe H / mm)	137
TP (Plattengröße / mm)	105x85
HS (Lochabstand / mm)	80x60
HD (Loch-Ø / mm)	8,5
SR (Schwenkradius / mm)	140
WB (Radlager)	Rollenlager