

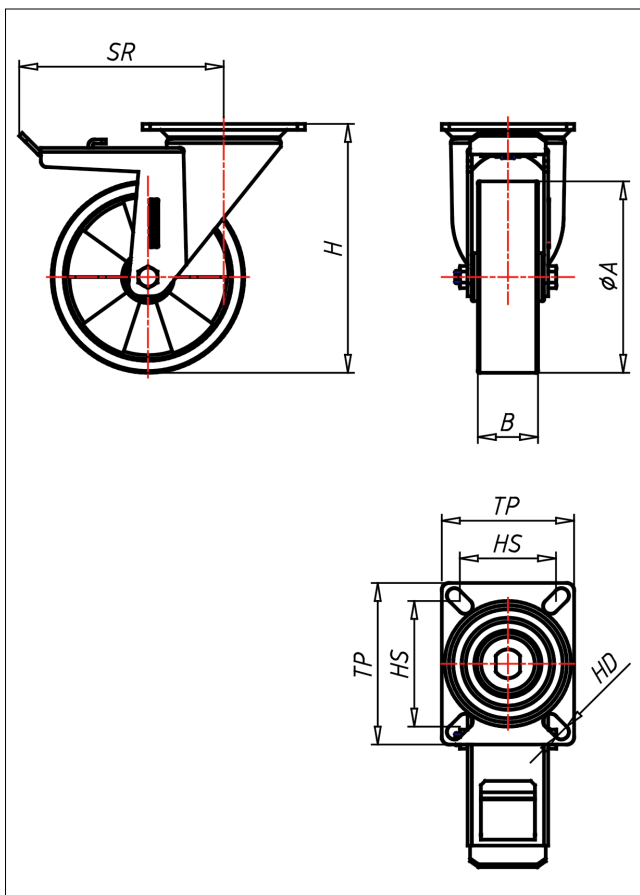

# KDT/KST-TLELK

## Lenkrolle mit Totalfeststeller

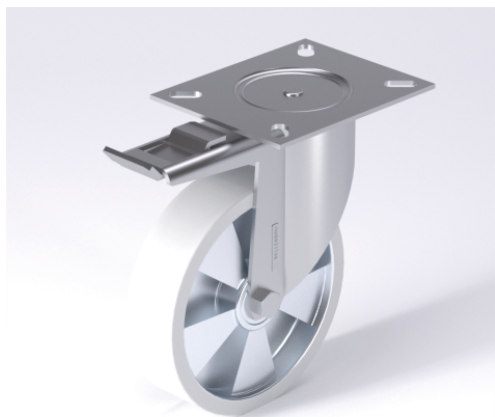

### KD-TLEL



**NEU!**

Lenkrolle Swivel Castor	Lenkrolle mit Totalfeststeller Swivel Castor with total lock	Bockrolle Fixed Castor
<ul style="list-style-type: none"> <li>elektrisch leitfähig</li> <li>geräuscharmer Lauf</li> <li>geringer Rollwiderstand</li> <li>stoß- und rollfest</li> <li>spurfrei</li> <li>stets beständig gegen viele aggressive Medien</li> </ul>	<ul style="list-style-type: none"> <li>Laufkugeln gehärtet, Kugelbahnen gepresst, starker Zentralzapfen</li> <li>verschraubt - gedichtet - gesichert</li> <li>Staubschuttring, verzinkt</li> </ul>	<ul style="list-style-type: none"> <li>Auswahlhilfe</li> <li>Selection Criteria</li> <li>leicht lenkbar/swivels easily</li> <li>verschleißarm/wear resistant</li> <li>stabil/floor proof</li> <li>bodenschonend/floor protection</li> <li>witterungsbeständig/weather proof</li> </ul>

→ Seite/Page 112

### Technische Details

<b>ORDERNO (Artikel-nummer)</b>	KDT 100 TLELK
<b>WDAB (Rad-Ø A x Breite B / mm)</b>	100x30
<b>LC (Tragkraft / kg)</b>	200
<b>H (Bauhöhe H / mm)</b>	137
<b>TP (Plattengröße / mm)</b>	105x85
<b>HS (Lochabstand / mm)</b>	80x60
<b>HD (Loch-Ø / mm)</b>	8.5
<b>SR (Schwenkradius / mm)</b>	140
<b>WB (Radlager)</b>	Kugellager