

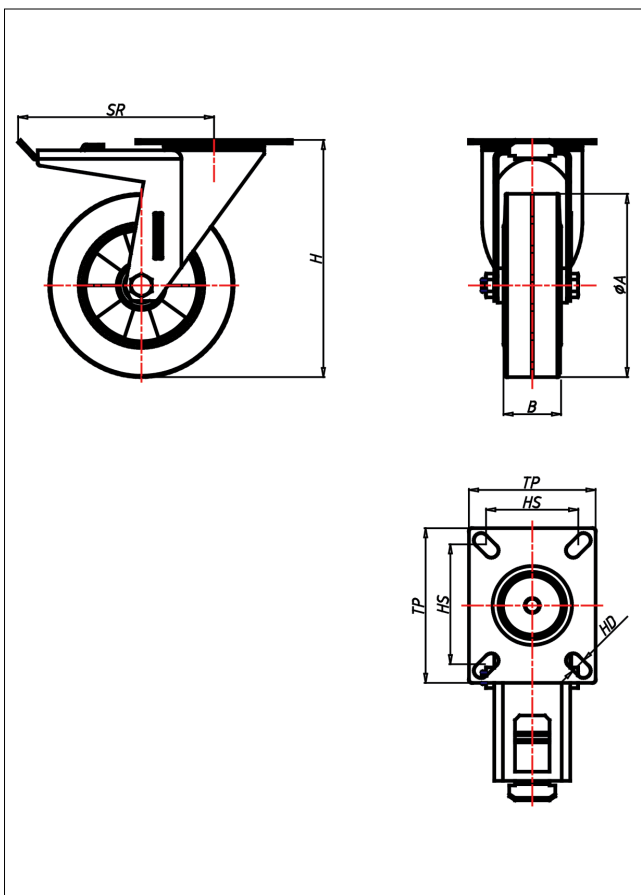

KDT/KST- EK/EB/LEK/LEB

Lenkrolle mit Totalfeststeller



KD-E



LENKROLLE	LENKROLLE MIT TOTALFESTSTELLER	BOCKROLLE															
																	
<ul style="list-style-type: none">• hoher Fahrkomfort• sehr lauffähig• geringer Rollwiderstand• abriebfest• spurfrei in grau	 <p>Laufkugeln gehärtet, Kugelbahnen gepresst, starker Zentralzapfen verschraubt - gedichtet - gesichert Staubschuttring, verzinkt</p> <p>→ Seite 62</p>	<p>AUSWAHLHILFE:</p> <table border="0"><tr><td>leicht lenkend</td><td>+</td><td>+</td></tr><tr><td>verschleißarm</td><td>+</td><td>X</td></tr><tr><td>stoßfest</td><td>+</td><td>X</td></tr><tr><td>bodenschonend</td><td>+</td><td>X</td></tr><tr><td>witterungsbeständig</td><td>X</td><td>+</td></tr></table>	leicht lenkend	+	+	verschleißarm	+	X	stoßfest	+	X	bodenschonend	+	X	witterungsbeständig	X	+
leicht lenkend	+	+															
verschleißarm	+	X															
stoßfest	+	X															
bodenschonend	+	X															
witterungsbeständig	X	+															

Technische Details

ORDERNO (Artikel-nummer)	KDT 200 EK
WDAB (Rad-Ø A x Breite B / mm)	200x50
LC (Tragkraft / kg)	450
H (Bauhöhe H / mm)	249
TP (Plattengröße / mm)	135x110
HS (Lochabstand / mm)	105x80
HD (Loch-Ø / mm)	12.5
SR (Schwenkradius / mm)	170
WB (Radlager)	Ball bearing