

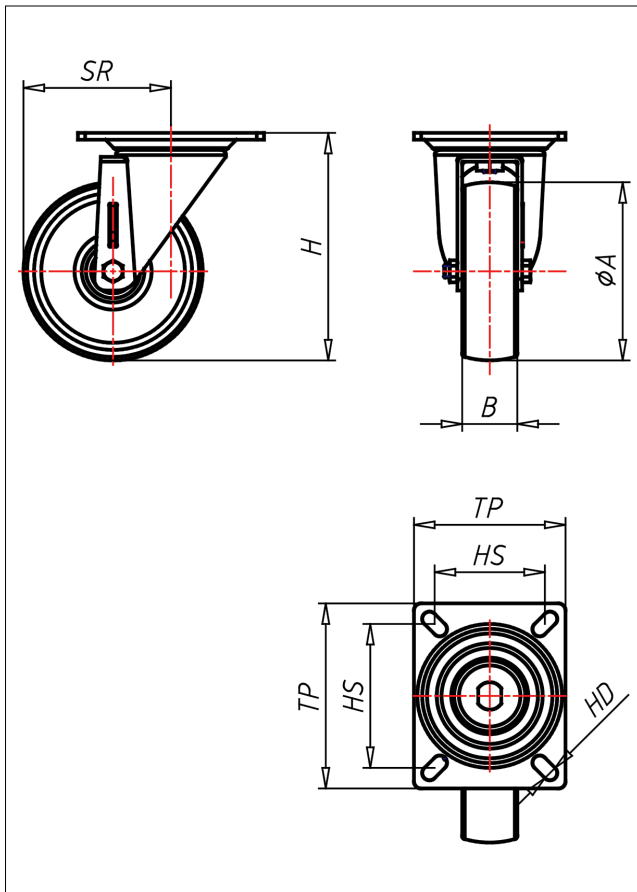

# PD/PS-Q/QK

## Lenkrolle

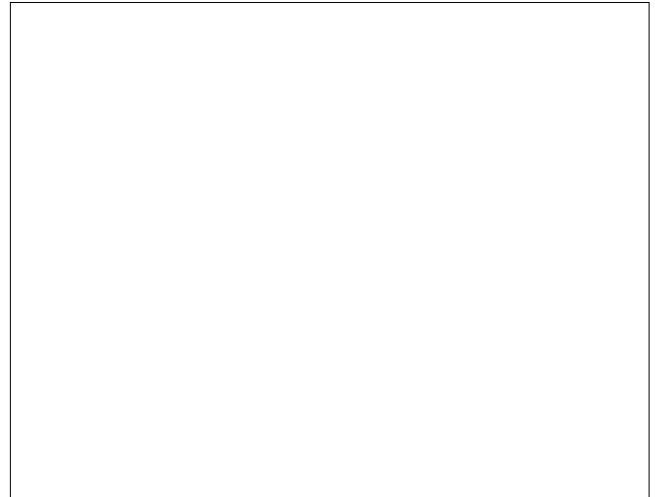

### PD-Q



| LENKROLLE   | LENKROLLE MIT TOTALFESTSTELLER  | BOCKROLLE  |                |   |   |    |               |   |  |  |          |  |  |   |               |   |  |  |                     |  |   |  |
|---|---|--|----------------|---|---|----|---------------|---|--|--|----------|--|--|---|---------------|---|--|--|---------------------|--|---|--|
|  <ul style="list-style-type: none"> <li>• leichter Lauf auf glatten Böden</li> <li>• sehr hohe Tragkraft</li> <li>• sehr abriebfest</li> </ul> <p>Gusseisen überdreht, lackiert</p> <p>→ Seite 270</p>  |   <p>gehärtete Stahlkugeln, zweifache Kugelbahnen aus gehärtetem Stahlblech, mit starkem Zentralzapfen verschraubt und gesichert - nachstellbar</p> <p>→ Seite 42</p> |  <p>AUSWAHLHILFE:</p> <table border="1"> <tr> <td>leicht lenkend</td> <td>-</td> <td>+</td> <td>++</td> </tr> <tr> <td>verschleißarm</td> <td>x</td> <td></td> <td></td> </tr> <tr> <td>stoßfest</td> <td></td> <td></td> <td>x</td> </tr> <tr> <td>bodenschonend</td> <td>x</td> <td></td> <td></td> </tr> <tr> <td>witterungsbeständig</td> <td></td> <td>x</td> <td></td> </tr> </table> | leicht lenkend | - | + | ++ | verschleißarm | x |  |  | stoßfest |  |  | x | bodenschonend | x |  |  | witterungsbeständig |  | x |  |
| leicht lenkend  | -   | +  | ++             |   |   |    |               |   |  |  |          |  |  |   |               |   |  |  |                     |  |   |  |
| verschleißarm   | x   |  |                |   |   |    |               |   |  |  |          |  |  |   |               |   |  |  |                     |  |   |  |
| stoßfest  |   |  | x              |   |   |    |               |   |  |  |          |  |  |   |               |   |  |  |                     |  |   |  |
| bodenschonend   | x   |  |                |   |   |    |               |   |  |  |          |  |  |   |               |   |  |  |                     |  |   |  |
| witterungsbeständig   |   | x  |                |   |   |    |               |   |  |  |          |  |  |   |               |   |  |  |                     |  |   |  |

### Technische Details

|                                       |            |
|---------------------------------------|------------|
| <b>ORDERNO (Artikel-nummer)</b>       | PD 100 QK  |
| <b>WDAB (Rad-Ø A x Breite B / mm)</b> | 100x30     |
| <b>LC (Tragkraft / kg)</b>            | 450        |
| <b>H (Bauhöhe H / mm)</b>             | 138        |
| <b>TP (Plattengröße / mm)</b>         | 105x85     |
| <b>HS (Lochabstand / mm)</b>          | 80x60      |
| <b>HD (Loch-Ø / mm)</b>               | 8.5        |
| <b>SR (Schwenkradius / mm)</b>        | 92         |
| <b>WB (Radlager)</b>                  | Kugellager |