

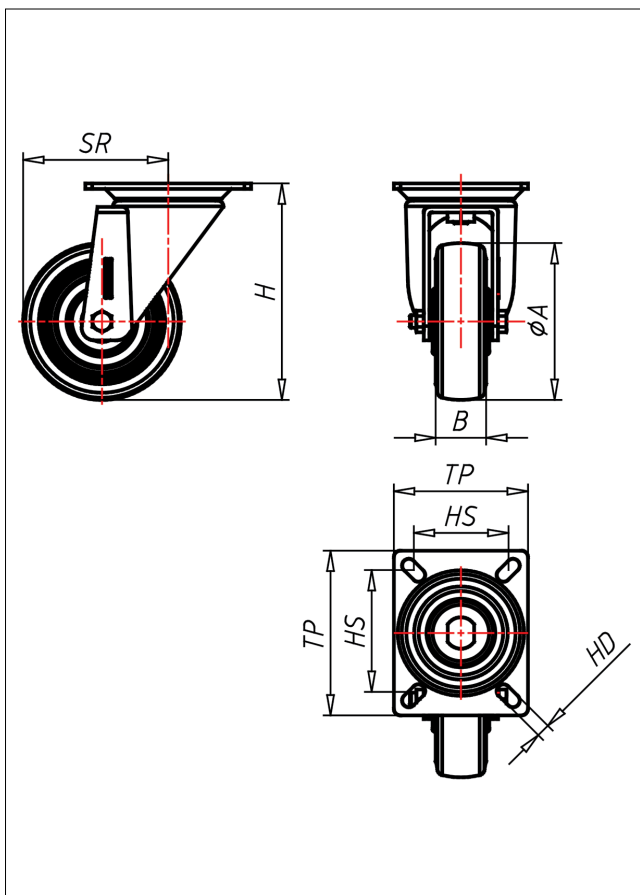

PD-AELK

Lenkrolle



PD-AEL



max. 500 kg



NEU!

Lenkrolle
Swivel Castor

- elektrisch leitfähig
- gerauschbarer Lauf
- geringer Rollwiderstand
- spurfrei
- hohe Stoßfestigkeit
- sehr beständig gegen viele aggressive Medien

Polymethan
Folge Polyamid 6
→ Seite/Page 335

Lenkrolle mit Totfallsteller
Swivel Castor with total lock

gehärtete Stahlkugeln, zweifache Kugelbahnen aus gehärtetem Stahlblech, mit starkem Zentralzapfen verschraubt und geschwächt-nachstellbar

→ Seite/Page 84

Bockrolle
Fixed Castor

Auswahlhilfe
Selection Criteria

leicht lenkbar/swivel easily	<input checked="" type="checkbox"/>	<input checked="" type="checkbox"/>	<input checked="" type="checkbox"/>
verschleißarm/wear resistant	<input checked="" type="checkbox"/>	<input checked="" type="checkbox"/>	<input checked="" type="checkbox"/>
staßfest/shock proof	<input checked="" type="checkbox"/>	<input checked="" type="checkbox"/>	<input checked="" type="checkbox"/>
bodenschonend/floor protective	<input checked="" type="checkbox"/>	<input checked="" type="checkbox"/>	<input checked="" type="checkbox"/>
witterungsbeständig/weather proof	<input checked="" type="checkbox"/>	<input checked="" type="checkbox"/>	<input checked="" type="checkbox"/>

Technische Details

ORDERNO (Artikel-nummer)	PD 125 AELK
WDAB (Rad-Ø A x Breite B / mm)	125X46
LC (Tragkraft / kg)	400
H (Bauhöhe H / mm)	164
TP (Plattengröße / mm)	135x110
HS (Lochabstand / mm)	105x80
HD (Loch-Ø / mm)	10.5
SR (Schwenkradius / mm)	104.5
WB (Radlager)	Kugellager