

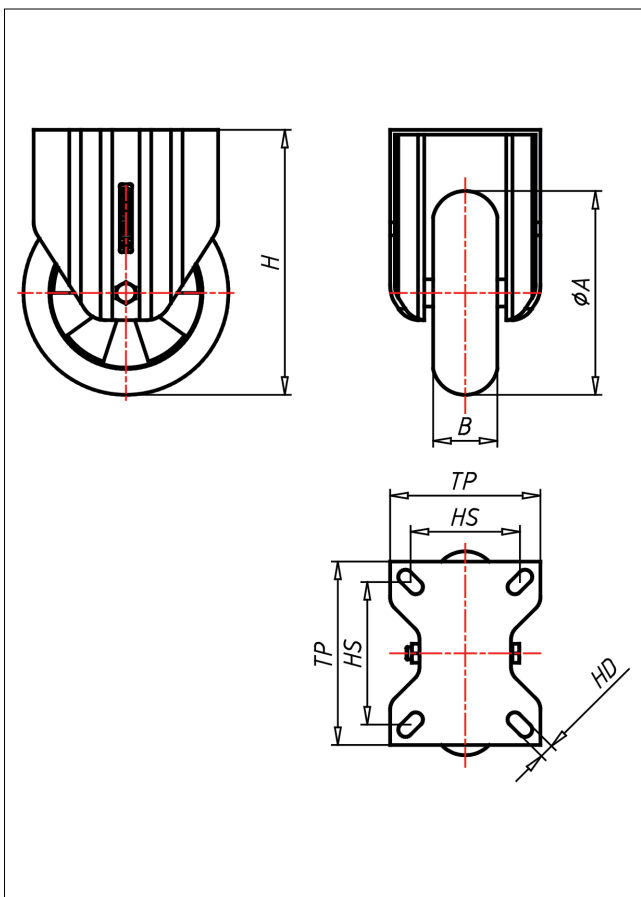

PDF-EGBAK

Bockrolle

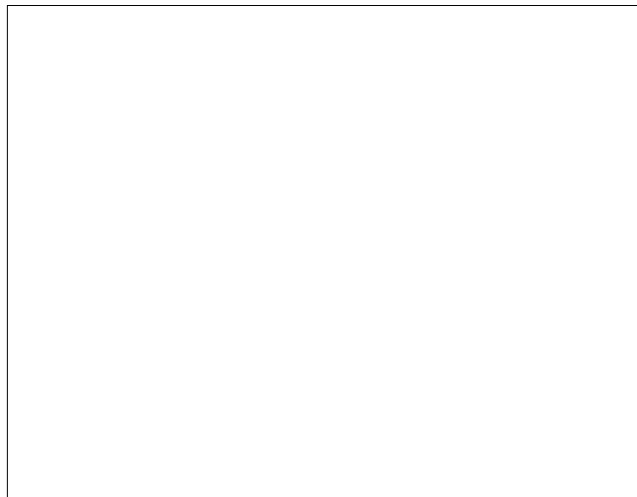
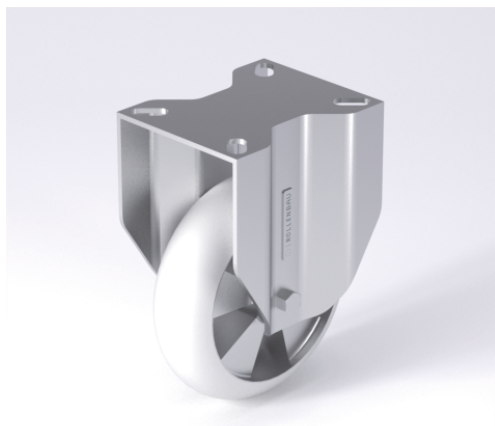

PD-EGBA



+80 °C
-30 °C
max. 450 kg



NEU!	Lenkrolle Swivel Castor	Lenkrolle mit Totfeststeller Swivel Castor with total lock	Bockrolle Fixed Castor																				
<ul style="list-style-type: none"> sehr geräuscharmer Lauf sehr geringer Rollwiderstand abriebfest korrosionsbeständig Alternative zu Luftreifen SPURFREI <p>Elastik-Vollgummireifen 55 ± 3 Shore A ballig Folge aus Spritzguss-Aluminium-Legierung → Seite/Page 345</p>	<p>gehärtete Stahlkugeln, zweifache Kugelbahnen aus gehärtetem Stahlblech, mit starkem Zentralszapfen verschraubt und gesichert - nachstellbar</p> <p>→ Seite/Page 84</p>	<p>Auswahlhilfe Selection Criteria</p> <table border="0"> <tr> <td>leicht lenkend/swivels easily</td> <td><input type="radio"/></td> <td><input checked="" type="radio"/></td> <td><input type="radio"/></td> </tr> <tr> <td>verschleißarm/wear resistant</td> <td><input type="radio"/></td> <td><input checked="" type="radio"/></td> <td><input type="radio"/></td> </tr> <tr> <td>stofffest/stock proof</td> <td><input type="radio"/></td> <td><input checked="" type="radio"/></td> <td><input type="radio"/></td> </tr> <tr> <td>bodenschonend/floor protective</td> <td><input type="radio"/></td> <td><input checked="" type="radio"/></td> <td><input type="radio"/></td> </tr> <tr> <td>witterungsbeständig/weather proof</td> <td><input type="radio"/></td> <td><input checked="" type="radio"/></td> <td><input type="radio"/></td> </tr> </table>	leicht lenkend/swivels easily	<input type="radio"/>	<input checked="" type="radio"/>	<input type="radio"/>	verschleißarm/wear resistant	<input type="radio"/>	<input checked="" type="radio"/>	<input type="radio"/>	stofffest/stock proof	<input type="radio"/>	<input checked="" type="radio"/>	<input type="radio"/>	bodenschonend/floor protective	<input type="radio"/>	<input checked="" type="radio"/>	<input type="radio"/>	witterungsbeständig/weather proof	<input type="radio"/>	<input checked="" type="radio"/>	<input type="radio"/>	
leicht lenkend/swivels easily	<input type="radio"/>	<input checked="" type="radio"/>	<input type="radio"/>																				
verschleißarm/wear resistant	<input type="radio"/>	<input checked="" type="radio"/>	<input type="radio"/>																				
stofffest/stock proof	<input type="radio"/>	<input checked="" type="radio"/>	<input type="radio"/>																				
bodenschonend/floor protective	<input type="radio"/>	<input checked="" type="radio"/>	<input type="radio"/>																				
witterungsbeständig/weather proof	<input type="radio"/>	<input checked="" type="radio"/>	<input type="radio"/>																				

Technische Details

ORDERNO (Artikel-nummer)	PDF 150 EGBAK
WDAB (Rad-Ø A x Breite B / mm)	150x47
LC (Tragkraft / kg)	270
H (Bauhöhe H / mm)	195
TP (Plattengröße / mm)	135x110
HS (Lochabstand / mm)	105x80
HD (Loch-Ø / mm)	10.5
SR (Schwenkradius / mm)	125
WB (Radlager)	Kugellager