

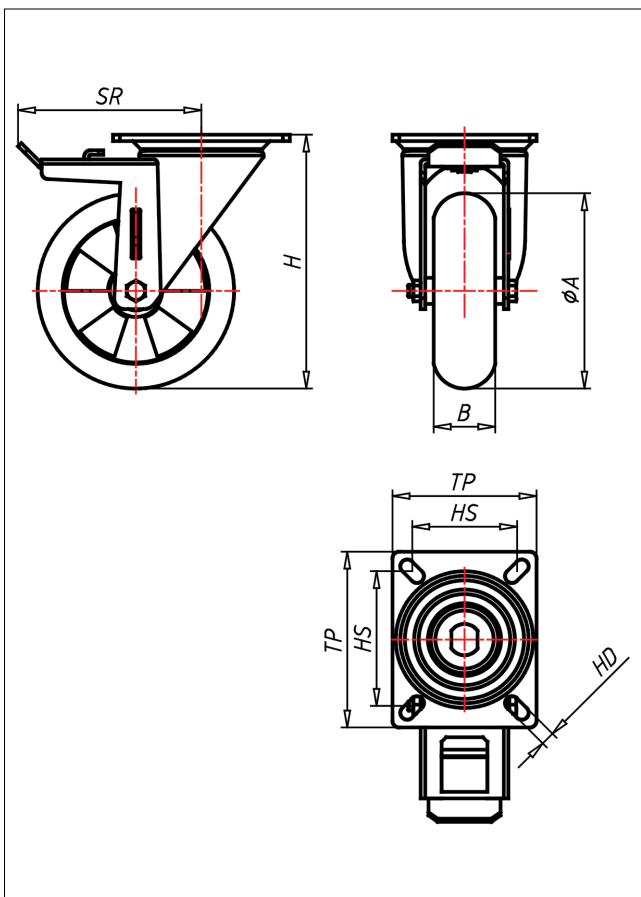

PDT-EBAK

Lenkrolle mit Totalfeststeller



PD-EBA



+80 °C
-30 °C
max. 450 kg



NEU!	Lenkrolle Swivel Castor	Lenkrolle mit Totalfeststeller Swivel Castor with total lock	Bockrolle Fixed Castor
<ul style="list-style-type: none"> sehr geräuscharmer Lauf sehr geringer Rollwiderstand abriebfest korrosionsbeständig Alternative zu Luftreifen 	<ul style="list-style-type: none"> gehärtete Stahlkugeln, zweifache Kugelbahnen aus gehärtetem Stahlblech, mit starkem Zentralspligen verschraubt und gesichert - nachstellbar 	<ul style="list-style-type: none"> leicht lenkend/swivels easily verschleißarm/wear resistant stofffest/stock proof bodenschonend/floor protective witterungsbeständig/weather proof 	<p>Auswahlhilfe Selection Criteria</p> <p>→ Seite/Page 84</p>

Technische Details

ORDERNO (Artikel-nummer)	PDT 150 EBAK
WDAB (Rad-Ø A x Breite B / mm)	150x47
LC (Tragkraft / kg)	270
H (Bauhöhe H / mm)	195
TP (Plattengröße / mm)	135x110
HS (Lochabstand / mm)	105x80
HD (Loch-Ø / mm)	10.5
SR (Schwenkradius / mm)	140
WB (Radlager)	Kugellager