

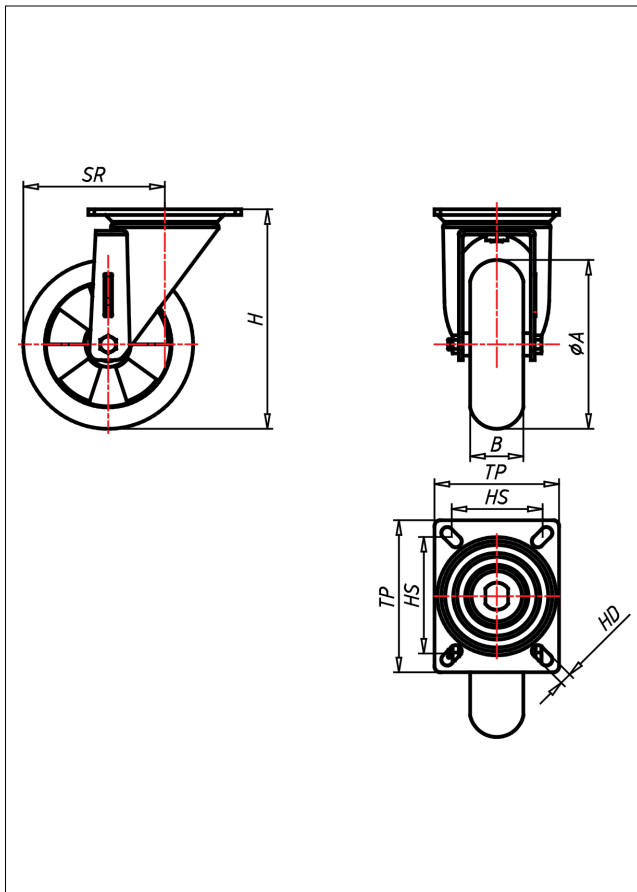

# PD-EBAK

## Lenkrolle

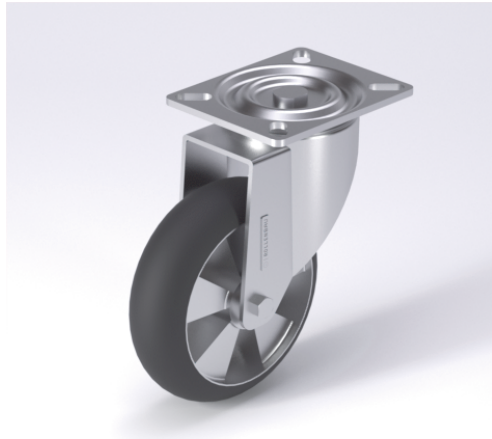

### PD-EBA



+80 °C  
-30 °C  
max. 450 kg



NEU!	Lenkrolle Swivel Castor	Lenkrolle mit Totfeststeller Swivel Castor with total lock	Bockrolle Fixed Castor
<ul style="list-style-type: none"> <li>sehr geräuscharmer Lauf</li> <li>sehr geringer Rollwiderstand</li> <li>abriebfest</li> <li>korrosionsbeständig</li> <li>Alternative zu Luftreifen</li> </ul>	<ul style="list-style-type: none"> <li>gehärtete Stahlkugeln, zweifache Kugelbahnen aus gehärtetem Stahlblech, mit starkem Zentralspligen verschraubt und gesichert - nachstellbar</li> </ul>	<ul style="list-style-type: none"> <li>leicht lenkend/swivels easily</li> <li>verschleißarm/wear resistant</li> <li>stofffest/stock proof</li> <li>bodenschonend/floor protective</li> <li>witterungsbeständig/weather proof</li> </ul>	<p>Auswahlhilfe Selection Criteria</p> <p>→ Seite/Page 84</p>

### Technische Details

ORDERNO (Artikel-nummer)	PS 160 EBAK
WDAB (Rad-Ø A x Breite B / mm)	160x50
LC (Tragkraft / kg)	270
H (Bauhöhe H / mm)	208
TP (Plattengröße / mm)	135x110
HS (Lochabstand / mm)	105x80
HD (Loch-Ø / mm)	12.5
SR (Schwenkradius / mm)	143
WB (Radlager)	Kugellager