

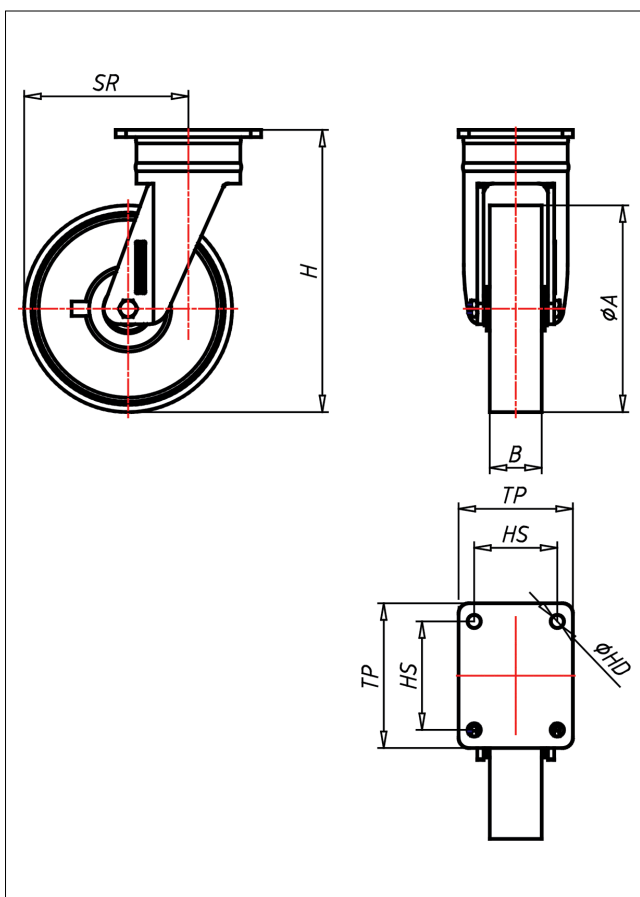

QD-PK/P

Lenkrolle



QD-P



LENKROLLE	LENKROLLE MIT TOTALFESTSTELLER	BOCKROLLE															
<ul style="list-style-type: none"> • leichter Lauf auf glatten Böden • stoß- und schlagfest • hohe Abriebfestigkeit • leicht zu reinigen • sehr beständig gegen viele aggressive Medien Polyamid 6 - 1. Wahl → Seite 272	<p>Schrägrollen- und Axialkugellager, staubgeschützt, sehr starker Zentriertbolzen, Mütter gesichert, Schmiemispel Ausführung verzinkt → Seite 26</p>	AUSWAHLHILFE: <table border="1"> <tr><td>leicht lenkend</td><td>+</td><td>+</td></tr> <tr><td>verschleißarm</td><td>+</td><td>+</td></tr> <tr><td>stoßfest</td><td>+</td><td>+</td></tr> <tr><td>bodenschonend</td><td>+</td><td>+</td></tr> <tr><td>witterungsbeständig</td><td>+</td><td>+</td></tr> </table>	leicht lenkend	+	+	verschleißarm	+	+	stoßfest	+	+	bodenschonend	+	+	witterungsbeständig	+	+
leicht lenkend	+	+															
verschleißarm	+	+															
stoßfest	+	+															
bodenschonend	+	+															
witterungsbeständig	+	+															

Technische Details

ORDERNO (Artikel-nummer)	QD 161 PK
WDAB (Rad-Ø A x Breite B / mm)	160x40
LC (Tragkraft / kg)	850
H (Bauhöhe H / mm)	233
TP (Plattengröße / mm)	140x110
HS (Lochabstand / mm)	105x80
HD (Loch-Ø / mm)	12.5
SR (Schwenkradius / mm)	133
WB (Radlager)	Kugellager