

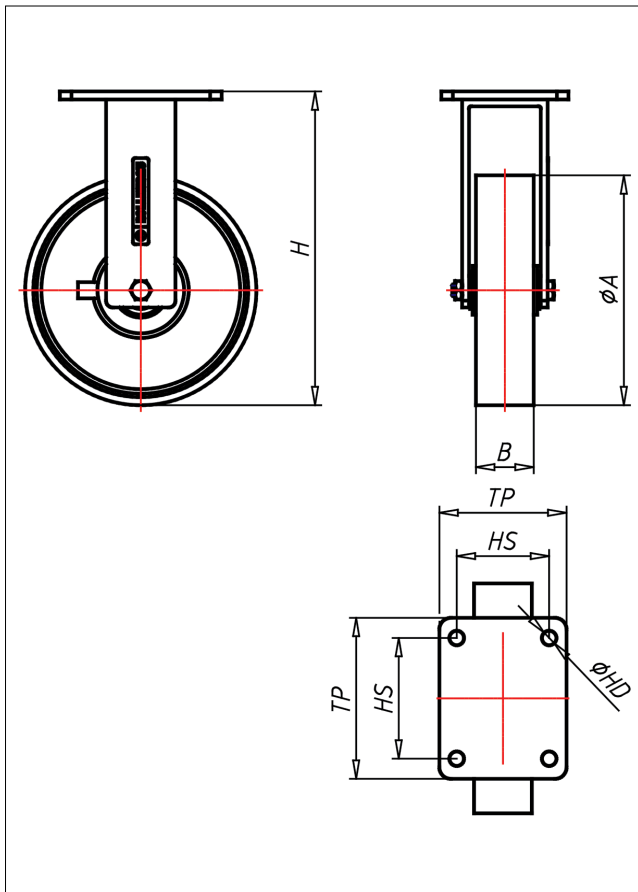

QDF-PK/P

Bockrolle



QD-P



| LENKROLLE | LENKROLLE MIT TOTALFESTSTELLER | BOCKROLLE | | | | | | | | | | | | | | | | | | | | |
|--|--|---|-------------------------------------|--------------------------|-------------------------------------|-------------------------------------|---------------|--------------------------|-------------------------------------|-------------------------------------|----------|--------------------------|-------------------------------------|-------------------------------------|---------------|--------------------------|-------------------------------------|-------------------------------------|---------------------|--------------------------|-------------------------------------|-------------------------------------|
| | | | | | | | | | | | | | | | | | | | | | | |
| <ul style="list-style-type: none"> • leichter Lauf auf glatten Böden • stoß- und schlagfest • hohe Abriebfestigkeit • leicht zu reinigen • sehr beständig gegen viele aggressive Medien Polyamid 6 - 1. Wahl → Seite 272 | Schrägrollen- und Axialkugellager, staubgeschützt, sehr starker Zentriertroben, Mütter gesichert, Schmiemoppel Ausführung verzinkt → Seite 26 | AUSWAHLHILFE: <table border="0"> <tr> <td>leicht lenkend</td> <td><input type="checkbox"/></td> <td><input checked="" type="checkbox"/></td> <td><input checked="" type="checkbox"/></td> </tr> <tr> <td>verschleißarm</td> <td><input type="checkbox"/></td> <td><input checked="" type="checkbox"/></td> <td><input checked="" type="checkbox"/></td> </tr> <tr> <td>stoßfest</td> <td><input type="checkbox"/></td> <td><input checked="" type="checkbox"/></td> <td><input checked="" type="checkbox"/></td> </tr> <tr> <td>bodenschonend</td> <td><input type="checkbox"/></td> <td><input checked="" type="checkbox"/></td> <td><input checked="" type="checkbox"/></td> </tr> <tr> <td>witterungsbeständig</td> <td><input type="checkbox"/></td> <td><input checked="" type="checkbox"/></td> <td><input checked="" type="checkbox"/></td> </tr> </table> | leicht lenkend | <input type="checkbox"/> | <input checked="" type="checkbox"/> | <input checked="" type="checkbox"/> | verschleißarm | <input type="checkbox"/> | <input checked="" type="checkbox"/> | <input checked="" type="checkbox"/> | stoßfest | <input type="checkbox"/> | <input checked="" type="checkbox"/> | <input checked="" type="checkbox"/> | bodenschonend | <input type="checkbox"/> | <input checked="" type="checkbox"/> | <input checked="" type="checkbox"/> | witterungsbeständig | <input type="checkbox"/> | <input checked="" type="checkbox"/> | <input checked="" type="checkbox"/> |
| leicht lenkend | <input type="checkbox"/> | <input checked="" type="checkbox"/> | <input checked="" type="checkbox"/> | | | | | | | | | | | | | | | | | | | |
| verschleißarm | <input type="checkbox"/> | <input checked="" type="checkbox"/> | <input checked="" type="checkbox"/> | | | | | | | | | | | | | | | | | | | |
| stoßfest | <input type="checkbox"/> | <input checked="" type="checkbox"/> | <input checked="" type="checkbox"/> | | | | | | | | | | | | | | | | | | | |
| bodenschonend | <input type="checkbox"/> | <input checked="" type="checkbox"/> | <input checked="" type="checkbox"/> | | | | | | | | | | | | | | | | | | | |
| witterungsbeständig | <input type="checkbox"/> | <input checked="" type="checkbox"/> | <input checked="" type="checkbox"/> | | | | | | | | | | | | | | | | | | | |

Technische Details

| | |
|---------------------------------------|---------------------|
| ORDERNO (Artikel-nummer) | QDF 250 P |
| WDAB (Rad-Ø A x Breite B / mm) | 250x60 |
| LC (Tragkraft / kg) | 1200 |
| H (Bauhöhe H / mm) | 318 |
| TP (Plattengröße / mm) | 140x110 |
| HS (Lochabstand / mm) | 105x80 |
| HD (Loch-Ø / mm) | 12.5 |
| WB (Radlager) | Polyamid-Gleitlager |