

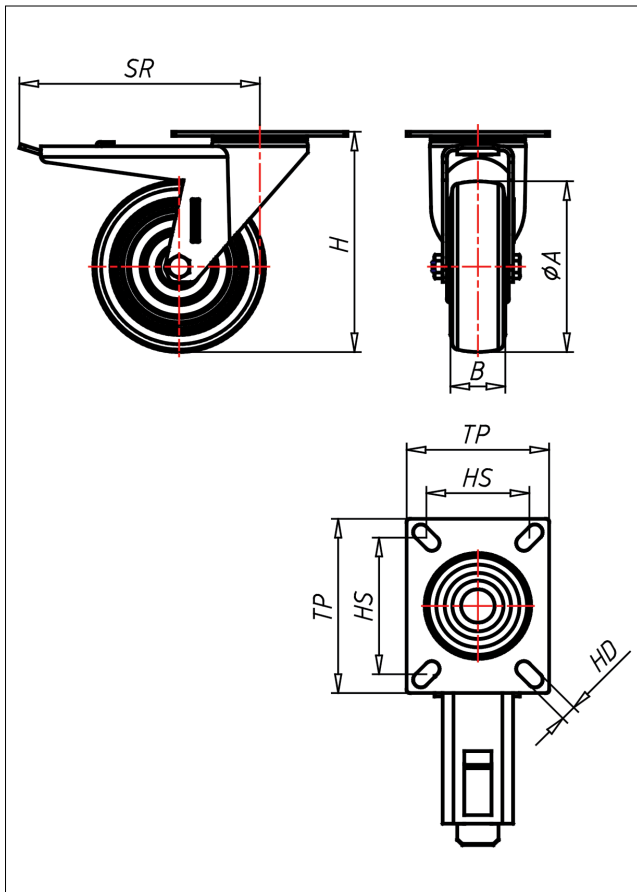

# XDT/XST/XSST-AELK

## Lenkrolle mit Totalfeststeller



XD-AEL



LENKROLLE	LENKROLLE MIT TOTALFESTSTELLER	BOCKROLLE																		
<ul style="list-style-type: none"> <li>• elektrisch leitfähig</li> <li>• geräuscharmer Lauf</li> <li>• geringer Rollwiderstand</li> <li>• sparfrees</li> <li>• hohe Stoßfestigkeit</li> <li>• sehr beständig gegen viele aggressive Medien</li> </ul> <p>Polyurethan Felge Polyamid 6 → Seite 255</p>	<p>zweifaches Kugellager – vernietet, Edelstahl AISI 304 poliert, Laufkugeln AISI 420, Staubschutzring, Radachse verschraubt</p> <p>→ Seite 110</p>	<p>AUSWAHLHILFE:</p> <table border="0"> <tr> <td>-</td> <td>+</td> <td>++</td> </tr> <tr> <td>leicht lenkend</td> <td>X</td> <td></td> </tr> <tr> <td>verschleißarm</td> <td></td> <td>X</td> </tr> <tr> <td>stoßfest</td> <td>X</td> <td></td> </tr> <tr> <td>bodenschonend</td> <td></td> <td>X</td> </tr> <tr> <td>witterungsbeständig</td> <td></td> <td>X</td> </tr> </table>	-	+	++	leicht lenkend	X		verschleißarm		X	stoßfest	X		bodenschonend		X	witterungsbeständig		X
-	+	++																		
leicht lenkend	X																			
verschleißarm		X																		
stoßfest	X																			
bodenschonend		X																		
witterungsbeständig		X																		

### Technische Details

<b>ORDERNO (Artikel-nummer)</b>	XDT 80 AELK
<b>WDAB (Rad-Ø A x Breite B / mm)</b>	80x32
<b>LC (Tragkraft / kg)</b>	120
<b>H (Bauhöhe H / mm)</b>	106
<b>TP (Plattengröße / mm)</b>	102x83
<b>HS (Lochabstand / mm)</b>	80x60
<b>HD (Loch-Ø / mm)</b>	9
<b>SR (Schwenkradius / mm)</b>	108
<b>WB (Radlager)</b>	Kugellager