

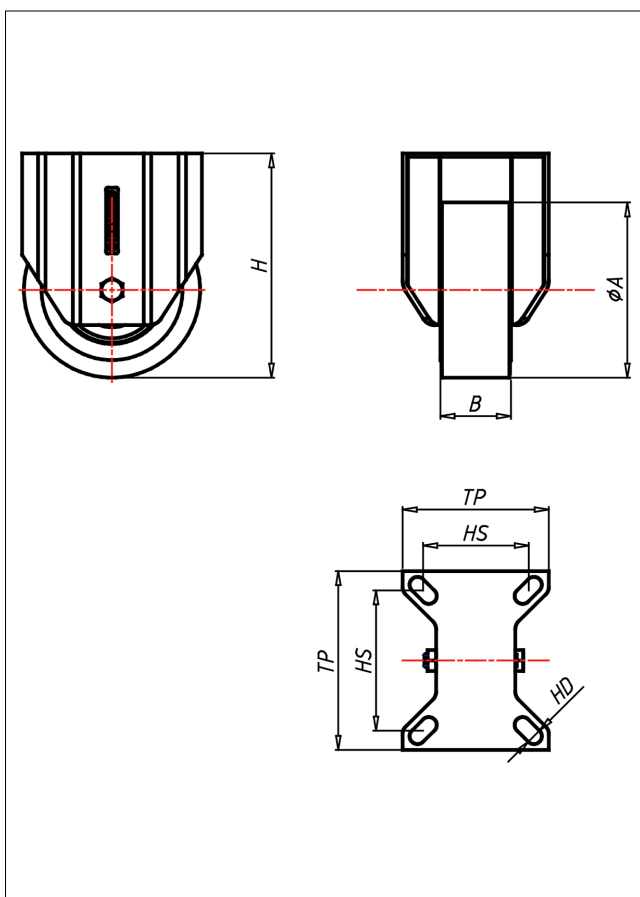

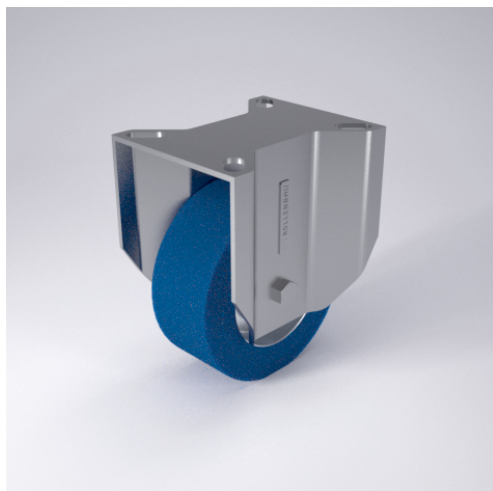

XF-HEK

Bockrolle



XDH-HE



LENKROLLE		
		
<ul style="list-style-type: none"> • geräuscharmer Lauf • geringer Anfahr- und Rollwiderstand • hitzebeständig bis 250 °C Silikon-Gummi blau Felge Aluminium → Seite 275	zweifaches Kugellager - vernietet, Staubschuttring, Edelstahl AISI 304, Laufkugeln AISI 420, Radachse verschraubt → Seite 160	AUSWAHLHILFE: leicht lenkend <input checked="" type="checkbox"/> <input checked="" type="checkbox"/> verschleißarm <input checked="" type="checkbox"/> <input checked="" type="checkbox"/> stoßfest <input checked="" type="checkbox"/> <input checked="" type="checkbox"/> bodenschonend <input checked="" type="checkbox"/> <input checked="" type="checkbox"/> witterungsbeständig <input checked="" type="checkbox"/> <input checked="" type="checkbox"/>

Technische Details

ORDERNO (Artikel-nummer)	XF 100 HEK
WDAB (Rad-Ø A x Breite B / mm)	100x40
LC (Tragkraft / kg)	80
H (Bauhöhe H / mm)	128
TP (Plattengröße / mm)	102x83
HS (Lochabstand / mm)	80x60
HD (Loch-Ø / mm)	9
WB (Radlager)	Kugellager