

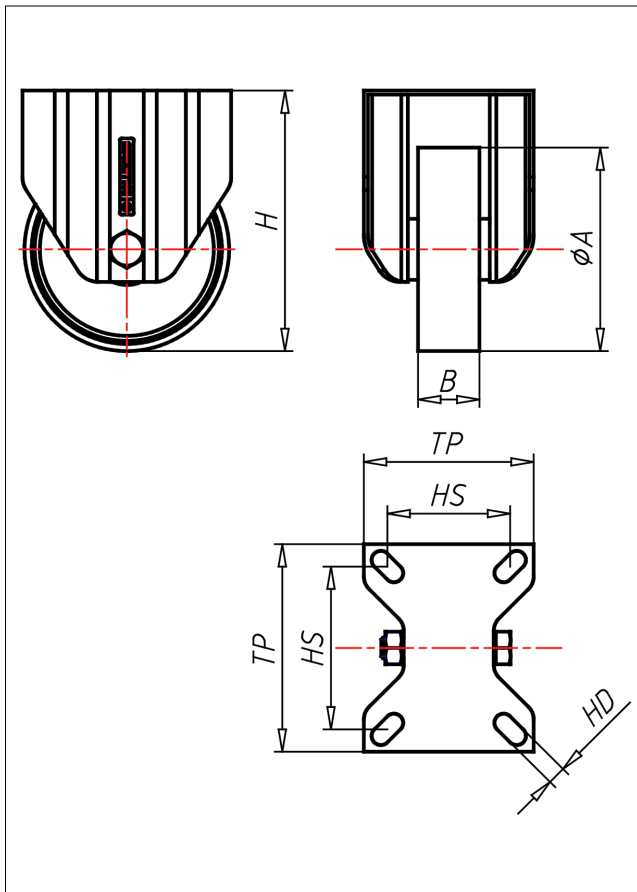

XF/XSF/XSSF/XLF- PBX/P/PL/PLL BX/PLL

Bockrolle

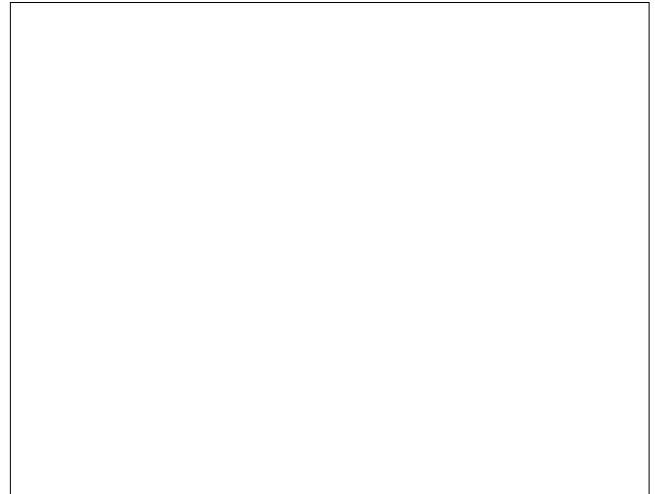
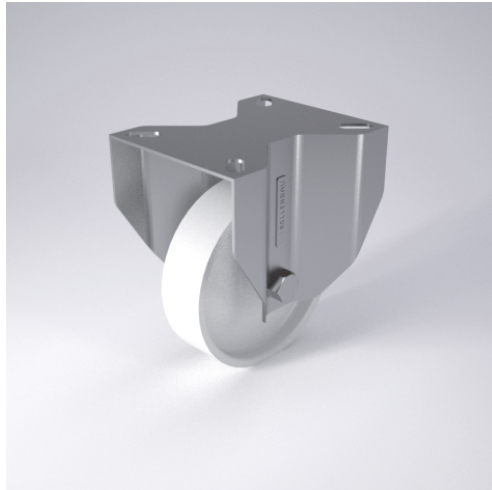

XD-P



LENKRÖLLE	LENKRÖLLE MIT TOTALFESTSTELLER	BOCKRÖLLE																		
<ul style="list-style-type: none"> • leichter Lauf auf glatten Böden • stoß- und schlagfest • hohe Abriebfestigkeit • leicht zu reinigen • sehr beständig gegen viele aggressive Medien Polyamid 6 - 1. Wahl → Seite 272	 zweifaches Kugellager - vernietet Edelstahl AISI 304 poliert, Laufkugeln AISI 420, Staubschutzring, Radachse verschraubt → Seite 110	AUSWAHLHILFE: <table border="0"> <tr> <td>•</td><td>+</td><td>++</td> </tr> <tr> <td>leicht lenkend</td><td>X</td><td></td> </tr> <tr> <td>verschleißarm</td><td></td><td>X</td> </tr> <tr> <td>stoßfest</td><td>X</td><td></td> </tr> <tr> <td>bodenschonend</td><td>X</td><td></td> </tr> <tr> <td>witterungsbeständig</td><td></td><td>X</td> </tr> </table>	•	+	++	leicht lenkend	X		verschleißarm		X	stoßfest	X		bodenschonend	X		witterungsbeständig		X
•	+	++																		
leicht lenkend	X																			
verschleißarm		X																		
stoßfest	X																			
bodenschonend	X																			
witterungsbeständig		X																		

Technische Details

ORDERNO (Artikel-nummer)	XF 175 P
WDAB (Rad-Ø A x Breite B / mm)	175x50
LC (Tragkraft / kg)	370
H (Bauhöhe H / mm)	216
TP (Plattengröße / mm)	135x110
HS (Lochabstand / mm)	105x80
HD (Loch-Ø / mm)	11
WB (Radlager)	Polyamid-Gleitlager