

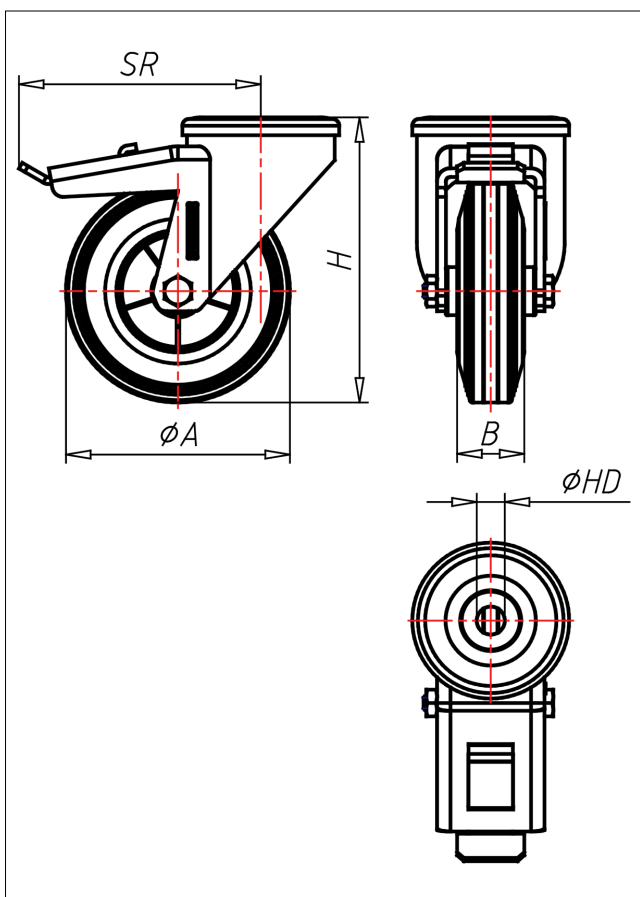

# XRT-DGBX/DG

## Lenkrolle mit Totalfeststeller



### XR-DG



LENKROLLE	LENKROLLE MIT TOTALFESTSTELLER																			
<ul style="list-style-type: none"> <li>• spurfrei - bodenschonend</li> <li>• hoher Fahrkomfort</li> <li>• sehr lauffähig</li> <li>• geringer Rollwiderstand</li> <li>• abriebfest</li> </ul> ELASTIK-Vollgummi Felge Kunststoff → Seite 202	zweifaches Kugellager - vernietet, Staubschutzing, Edelstahl AISI 304 poliert, Laufkugeln AISI 420, Radachse verschraubt → Seite	AUSWAHLHILFE: <table border="0"> <tr> <td>•</td><td>+</td><td>++</td> </tr> <tr> <td>leicht lenkend</td><td>X</td><td>●</td> </tr> <tr> <td>verschleißarm</td><td>●</td><td>●</td> </tr> <tr> <td>stoßfest</td><td>X</td><td>●</td> </tr> <tr> <td>bodenschonend</td><td>●</td><td>●</td> </tr> <tr> <td>witterungsbeständig</td><td>●</td><td>X</td> </tr> </table>	•	+	++	leicht lenkend	X	●	verschleißarm	●	●	stoßfest	X	●	bodenschonend	●	●	witterungsbeständig	●	X
•	+	++																		
leicht lenkend	X	●																		
verschleißarm	●	●																		
stoßfest	X	●																		
bodenschonend	●	●																		
witterungsbeständig	●	X																		

### Technische Details

<b>ORDERNO (Artikel-nummer)</b>	XRT 125 DG
<b>WDAB (Rad-Ø A x Breite B / mm)</b>	125x38
<b>LC (Tragkraft / kg)</b>	110
<b>H (Bauhöhe H / mm)</b>	154
<b>HD (Loch-Ø / mm)</b>	12.5
<b>SR (Schwenkradius / mm)</b>	108
<b>WB (Radlager)</b>	Polyamid-Gleitlager