

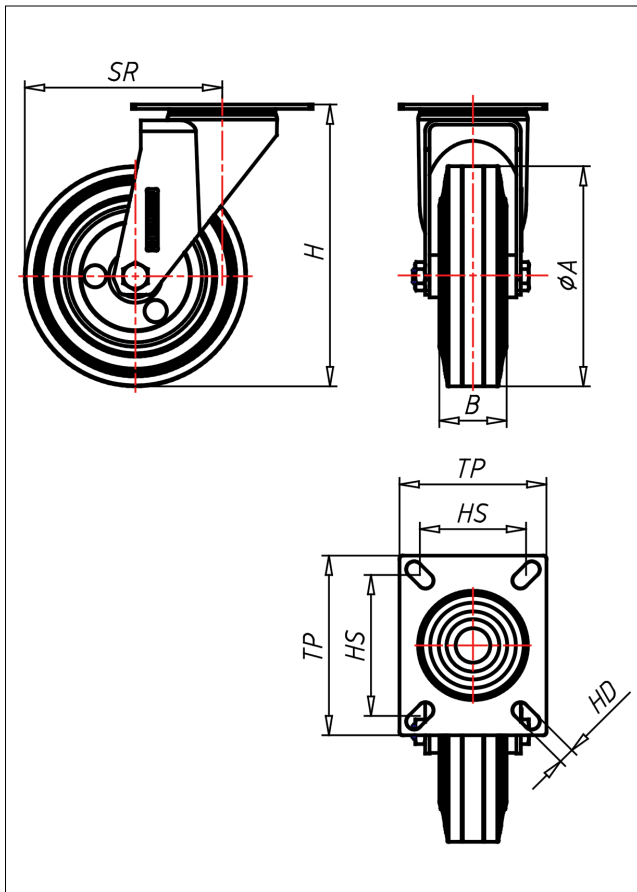

XD/XS/XSS-ELBX

Lenkrolle



XD-EL



LENKROLLE	LENKROLLE MIT TOTALFESTSTELLER	BOCKROLLE										
 <ul style="list-style-type: none"> • elektrisch leitfähig • Widerstand <math><10^{\circ}\Omega</math> • geräuscharmer Lauf • großer Fahrkomfort • beständig gegen verdünnte Säuren <p>Vollgummi schwarz Felge aus Edelstahl → Seite 207</p> 	  <p>zweifaches Kugellager - vernietet, Edelstahl ANSI 304 poliert, Laufkugeln ANSI 420, Staubschutzring, Radachse verschraubt → Seite 110</p>	 <p>AUSWAHLHILFE:</p> <table border="1"> <tr> <td>leicht lenkend</td> <td><input checked="" type="checkbox"/></td> </tr> <tr> <td>verschleißarm</td> <td><input checked="" type="checkbox"/></td> </tr> <tr> <td>stoßfest</td> <td><input checked="" type="checkbox"/></td> </tr> <tr> <td>bodenschonend</td> <td><input checked="" type="checkbox"/></td> </tr> <tr> <td>witterungsbeständig</td> <td><input checked="" type="checkbox"/></td> </tr> </table>	leicht lenkend	<input checked="" type="checkbox"/>	verschleißarm	<input checked="" type="checkbox"/>	stoßfest	<input checked="" type="checkbox"/>	bodenschonend	<input checked="" type="checkbox"/>	witterungsbeständig	<input checked="" type="checkbox"/>
leicht lenkend	<input checked="" type="checkbox"/>											
verschleißarm	<input checked="" type="checkbox"/>											
stoßfest	<input checked="" type="checkbox"/>											
bodenschonend	<input checked="" type="checkbox"/>											
witterungsbeständig	<input checked="" type="checkbox"/>											

Technische Details

ORDERNO (Artikel-nummer)	XS 125 ELBX
WDAB (Rad-Ø A x Breite B / mm)	125x38
LC (Tragkraft / kg)	100
H (Bauhöhe H / mm)	160
TP (Plattengröße / mm)	102x83
HS (Lochabstand / mm)	80x60
HD (Loch-Ø / mm)	9
SR (Schwenkradius / mm)	111.5
WB (Radlager)	Rollenlager